



R-flexTM
insulated piping systems

installation manual



Watts Radiant
Floor Heating & Snowmelting
A Watts Water Technologies Company

Table of Contents

Description 2
Specifications. 3
Warnings 3
Transportation 4
Connections 5
Utility Trenches 6
Wall Penetrations 8
Intersections 11
Inspection Chamber 15
Repairs. 19

Appendix

A - System Design 20
B - Pressure Drops. 25
C - Pressure Test Logs 30
D - Installation Times 31

Description

Well insulated piping systems equate to energy savings. Watts Radiant's R-flex™ series is a pre-insulated piping system composed of a thermal insulated jacket surrounding the carrier pipe(s). Each foot of R-flex is protected by a double wall high density polyethylene outer jacket.

R-flex is an SDR-11 PEX fluid transfer piping system suitable for use in heating or cooling applications. Each foot of R-flex is protected with an EVOH oxygen diffusion layer. Low weight and superior flexibility means R-flex can be installed easily and rapidly, even over obstacles or around corners.

R-flex is available with either a single or double carrier pipe in a wide variety of sizes, all offering superior insulation properties. The insulating material consists of microcellular, cross-linked polyethylene foam. The closed-cell structure of the foam provides excellent insulation values, ensures minimal water absorption, and is CFC free.

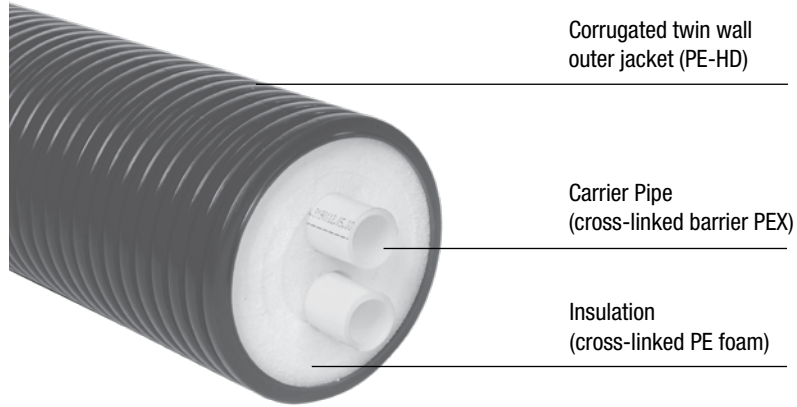

Carrier pipes in Dual R-flex are marked with a single dash line and a double dashed line to provide easy identification at transition points.

The outer shell of R-flex is constructed of double-wall, high density corrugated polyethylene. A durable, watertight seal is provided between the inner and outer surface, ensuring that moisture ingress is prevented in the event that the outer casing is damaged. This unique combination of inner and outer layers also allows the corrugated design of the outer shell to bend easier, providing greater flexibility.

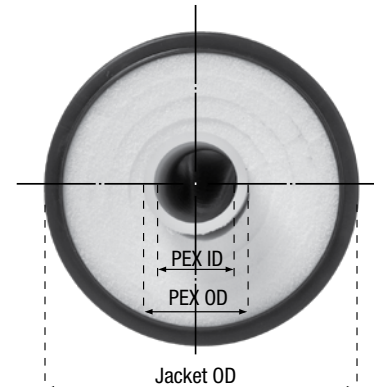

Specifications (conforms to DIN 16892, SDR-11)															
	Order #	Description	PEX ID	PEX OD	Jacket OD	Bend Radius	Coil Length	Coil Diameter	Coil Height	Coil Weight	Fluid Cap. / 100m (328ft)	Insulation Thickness	Casing R-Value		
Single	81012929	160/40 R-flex	32.6 mm (1.28")	40 mm (1.57")	160 mm (6.30")	350 mm (13.8")	100 m** (328 ft)	2300 mm (90.6")	850 mm (33.50")	232 kg (512 lbs)	83.00 L (21.93 gal)	47.5 mm (1.88")	6.79		
	81012886	160/50 R-flex	40.8 mm (1.61")	50.0 mm (1.97")		450 mm (17.80")				248 kg (547 lbs)	131.31 L (34.69 gal)	42.5 mm (1.68")	6.07		
	81012887	160/63 R-flex	51.6 mm (2.03")	63.0 mm (2.48")		550 mm (21.7")				278 kg (613 lbs)	208.76 L (55.15 gal)	37.0 mm (1.46")	5.27		
	81012889	200/75 R-flex	61.4 mm (2.42")	75.0 mm (2.95")	200 mm (7.90")	800 mm (31.5")			1400 mm (55.20")	416 kg (917 lbs)	296.67 L (78.37 gal)	52.0 mm (2.05")	7.4		
	81012890	200/90 R-flex	73.6 mm (2.90")	90.0 mm (3.54")		1100 mm (43.4")				473 kg (1,043 lbs)	426.02 L (112.55 gal)	44.0 mm (1.74")	6.28		
	81012891	200/110 R-flex	90.0 mm (3.55")	110.0 mm (4.33")		1200 mm (47.3")				564 kg (1,244 lbs)	638.41 L (168.65 gal)	34.0 mm (1.33")	4.84		
Dual	81012879	125/2x1 R-flex*	0.863" (21.92 mm)	1.125" (28.58 mm)	4.90" (125 mm)	11.80" (300 mm)	100 m** (328 ft)	2300 mm (90.60")	82.70" (2100 m)	27.60" (700 mm)	358 lbs (162 kg)	19.94 gal (75.46 L)	1.11" (28.0 mm)	4.01	
	81012880	125/2x32 R-flex	26.2 mm (1.03")	32.0 mm (1.26")	125 mm (4.90")	300 mm (11.80")									2100 mm (82.70")
	81012882	160/2x40 R-flex	32.6 mm (1.28")	40.0 mm (1.57")	160 mm (6.30")	600 mm (23.70")			200 mm (7.90")	1400 mm (55.20")	850 mm (33.50")	263 kg (580 lbs)	166.00 L (43.86 gal)	34.0 mm (1.34")	4.84
	81012884	200/2x50 R-flex	40.8 mm (1.61")	50.0 mm (1.97")	800 mm (31.50")	403 kg (889 lbs)					262.62 L (69.38 gal)	46.0 mm (1.81")	6.57		
	81012885	200/2x63 R-flex	51.6 mm (2.03")	63.0 mm (2.48")	1200 mm (47.30")	464 kg (1,023 lbs)					417.52 L (110.30 gal)	33.0 mm (1.30")	4.69		

* Pex pipe is certified to ASTM F876, SDR-9 dimensions.

** Custom lengths are available upon request. Contact distributor for details.

⚠ WARNINGS

General Handling & Storage

If R-flex connections must be made in temperatures lower than 30°F, caution must be taken to allow the tubing to form a proper seal against the barb. Apply the connection slowly to ensure the PEX material conforms to the barb.

In order to prevent property damage, serious injury and/or death...

- Do not allow the fluid temperature to exceed:
 - 200°F at 80psi
 - 180°F at 100psi
 - 73.4°F at 160psi
- Do not allow the inner PEX tubing to be exposed to sunlight, or direct UV exposure for more than 30 days maximum. Outer casing of R-flex protects the inner PEX tubing from UV exposure.
- Do not allow the tubing to come in contact with any of the following:
 - Petroleum based products
 - Pipe sealants
 - Firewall sealants (except those approved to be used with PEX)
- Do not use if the tubing has visible gouges, cuts, cracks, abrasions, signs of physical damage, or other defects.
- Do not use in swimming pools or other systems that use high levels of chlorine.
- Do not kink. If kinking occurs, use a repair coupling.
- Do not expose tubing to rough terrain that may cause punctures, cuts, or other damage.
- Do not use tubing to transfer natural gas or any unapproved substances.
- Do not use Crimp, Cinch, or Compression connections designed for RadiantPEX or RadiantPEX+ with metric size R-flex tubing.**

- Kerosene
- Gasoline
- Fuel oils
- Cutting oils
- Asphalt
- Contaminated soils or building materials.

General Installation Cautions

1. When installing R-flex, use a serpentine pattern to account for expansion and contraction. Failure to do so may result in damage to connections.
2. Do not install directly to a heat source. A metallic adapter, minimum 18" in length, must be used between the heat source and tubing.
3. Do not support fixtures directly from the tubing, such as hose bibs or shut-off valves.
4. Protect the tubing via sleeves where it transitions through a concrete slab, concrete wall or other framing material.
5. Do not use this manual to install Watts Radiant Onix™, RadiantPEX™, RadiantPEX+™, or RadiantPEX-AL™.

Transport and Storage

R-flex pipelines are supplied in coils with a maximum length of 328 ft (100 meters). Pipe ends are factory sealed with protective end caps to prevent dirt and debris from entering the tubing.

In storage, care must be taken to ensure that the PEX carrier pipe is protected from sunlight and that no undesirable deformation of the coil occurs.

Pipes must be transported and stored in such a way that sharp objects, like stones and tree roots cannot damage them. Pipes must not be dragged along the ground. **Only nylon or textile straps should be used for fastening the coils during transport.**

Connections

R-flex connections are specifically designed and engineered for hydronic heating and cooling applications. They are available in PEX x NPT adapters. Tees and elbows can be constructed with the use of an NPT tee or elbow.

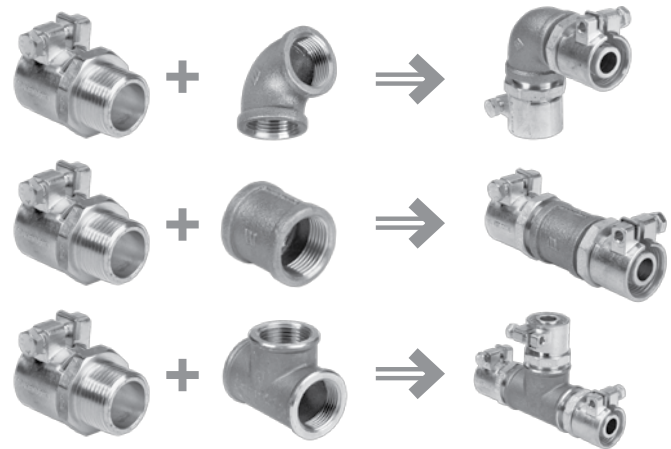
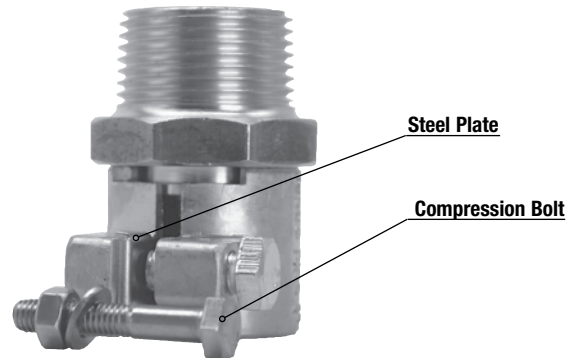
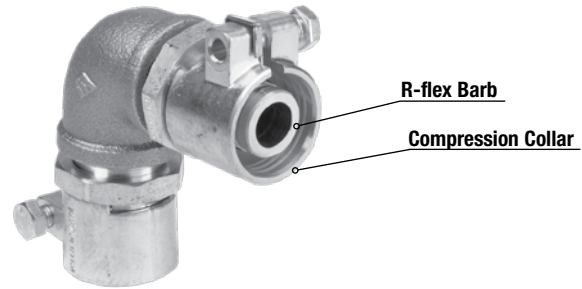

Standard NPT Tees, Elbows, and Couplings are used with R-flex fittings to create a wide range of fitting configurations.

Assembly instructions

- 1 Cut the PEX pipe at a right angle with a pair of PEX cutters.
- 2 If the tubing is cut by a saw, deburr the pipe with an appropriate tool.
- 3 & 4 The compression fitting comes with a nut and steel plate. Use these to open the compression collar and allow the collar to slide off of the NPT base.
- 5 Slide the compression collar over the pipe. Ensure the notch on the inside of the clamping ring is facing the fitting.
- 6 Push the pipe COMPLETELY over the coupling.
- 7 Slide the clamping ring back to COMPLETELY cover the fitting.
- 8 Remove the bolt and the steel plate.
- 9 & 10 Assemble the bolt, washer and nut provided and tighten the compression collar to the following torque recommendations:

R-flex Diameter	Bolt Size	Torque
1" (USA / Canada)	M 8	8 Nm (5.9 ft-lbf)
32 mm	M 8	8 Nm (5.9 ft-lbf)
40 mm	M 8	10 Nm (7.38 ft-lbf)
50 mm	M 10	40 Nm (29.50 ft-lbf)
63 mm	M 12	70 Nm (51.63 ft-lbf)
75 mm	M 12	70 Nm (51.63 ft-lbf)
90 mm	M 16	110 Nm (81.13 ft-lbf)
110 mm	M 16	110 Nm (81.13 ft-lbf)

Test Connections:

1. Preliminary test

The preliminary test involves applying a test pressure equal to 1.5 times the admissible operating pressure. This pressure must be regenerated twice within the space of 30 minutes at intervals of 10 minutes. Following a test period of another 30 minutes, the test pressure must not have fallen by more than 9 psi. Leaks must not occur at any points in the system being tested.

2. Main test

The main test has to be conducted immediately after the preliminary test. The test takes 2 hours. At the end of this period, the test pressure recorded after the preliminary test must not have fallen by more than 3 psi. Leaks must not occur at any point in the system being tested.

(See Appendix C on page 30 for time-pressure curve of test method and log for test results)

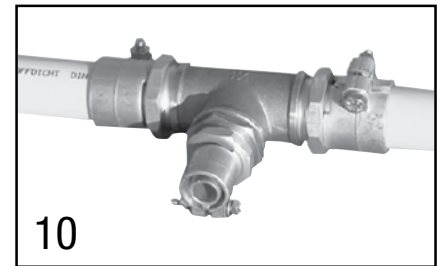
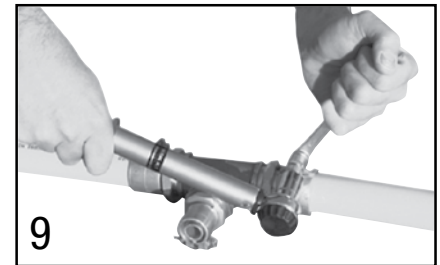
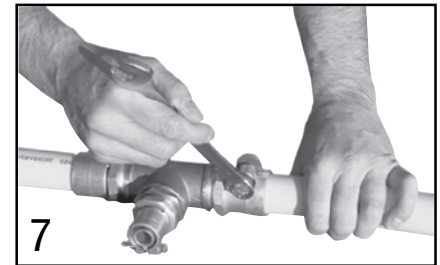
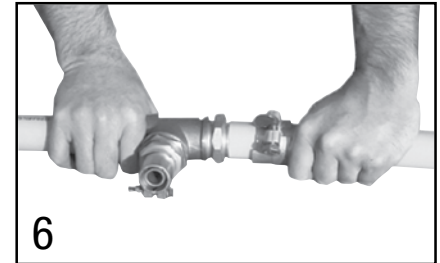
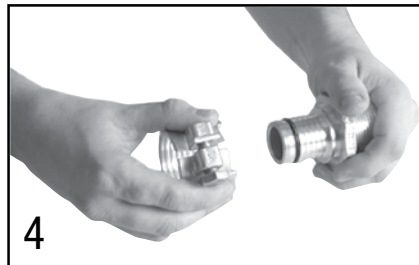
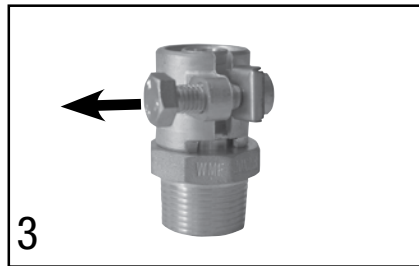
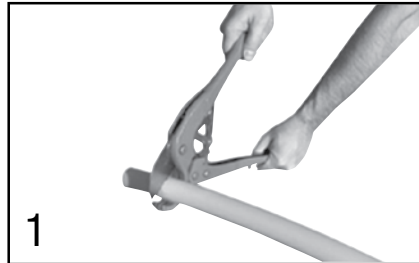

Utility Trench Profile

Trenches 4ft (120 cm) or less can be dug with vertical walls. If the trench is to be deeper than 4 ft (120 cm), a V-shaped trench should be dug to prevent accidental wall-collapse.

Excavation work must be carried out in the approved manner, according to the rules and regulations of local authorities.

The depth of the trench must be in accordance with the guidelines relating to the laying of R-flex.

It is recommended to consult with the local utility company to have the area marked for public utilities such as water, gas, electrical, and phone.

After completion of the pipe-laying process, the route can be marked with warning tape.

Minimum laying temperature for R-flex is 23°F (- 5°C).

- 1 Backfill
- 2 Route warning tape - to indicate buried pipe underfoot
- 3 Sand fill
- 4 Sandbed
- 5 R-flex

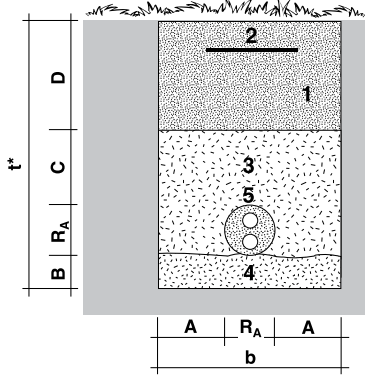

Profile of trench for R-flex Dual (twin) pipe

R _A jacket Ø mm	A mm	B mm	C mm	D mm pedestrian	D mm vehicular	b width mm	t* depth mm pedestrian	t* depth mm vehicular	Excavation m ³ /m approx	Sandfill m ³ /m approx
125 (5.00 in)	150 (6.00 in)					425 (16.75 in)	625 (24.61 in)	1025 (40.35 in)	0.27 (9.53 ft ³ /ft)	0.17 (6.00 ft ³ /ft)
160 (6.23 in)	180 (7.10 in)	100 (4.00 in)	150 (6.00 in)	250 (9.85")	650 (25.60")	520 (20.50 in)	660 (25.98 in)	1060 (41.73 in)	0.34 (12.00 ft ³ /ft)	0.22 (7.77 ft ³ /ft)
200 (7.87 in)						560 (22.05 in)	700 (27.56 in)	1100 (43.31 in)	0.39 (13.75 ft ³ /ft)	0.25 (8.83 ft ³ /ft)

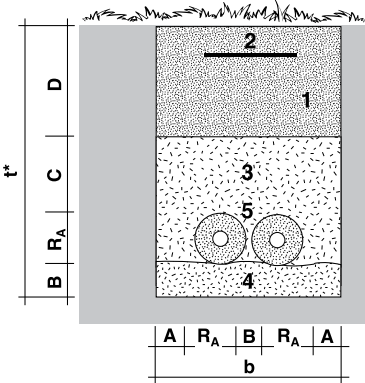

Profile of trench for (2) R-flex single pipes (2x Dual) WITHOUT underground connection

R _A jacket Ø mm	A mm	B mm	C mm	D mm pedestrian	D mm vehicular	b width mm	t* depth mm pedestrian	t* depth mm vehicular	Excavation m ³ /m approx	Sandfill m ³ /m approx
125 (5.00 in)	150 (6.00 in)					650 (25.60 in)	625 (24.61 in)	1025 (40.35 in)	0.41 (14.50 ft ³ /ft)	0.26 (9.20 ft ³ /ft)
160 (6.23 in)	180 (7.10 in)	100 (4.00 in)	150 (6.00 in)	250 (9.85")	650 (25.60")	780 (30.71 in)	660 (25.98 in)	1060 (41.73 in)	0.51 (18.01 ft ³ /ft)	0.32 (11.30 ft ³ /ft)
200 (7.87 in)						860 (33.86 in)	700 (27.56 in)	1100 (43.31 in)	0.60 (21.12 ft ³ /ft)	0.38 (13.42 ft ³ /ft)

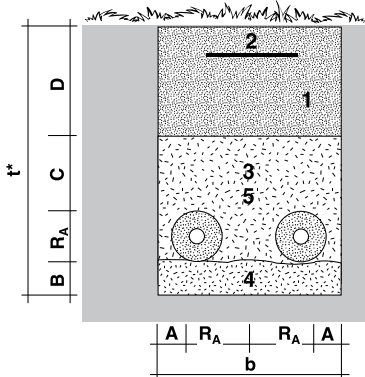

Profile of trench for (2) R-flex single pipes WITH underground connection

R _A mm	A mm	B mm	C mm	D mm pedestrian	D mm vehicular	b width mm	t* depth mm pedestrian	t* depth mm vehicular	Excavation m ³ /m approx	Sandfill m ³ /m approx
300 (12.00 in)	150 (6.00 in)	100 (4.00 in)	150 (6.00 in)	250 (9.85")	650 (25.60")	900 (36.00 in)	800 (31.50 in)	1200 (47.24 in)	0.72 (25.43 ft ³ /ft)	0.45 (15.90 ft ³ /ft)

Install R-flex in accordance to local code requirements. Depth of R-flex should be compliant with intended loads.

Profiles of Typical Utility Trenches

Trench depth should allow the R-flex to rest below normal frost line. Failure to do so will accelerate heat loss through the tubing. Check local codes to determine minimum pipe depth with relation to surface loads. Local codes may require different depths than those illustrated in this manual.

Instructions for Laying R-flex

R-flex can easily be placed in earth-contact trenches. The corrugated jacket provides the necessary protection for the insulating material and the PEX pipe. Groundwater has no influence on the R-flex system. When laying the R-flex directly into the trench, be careful not to pull the piping by the outer jacket. Doing so may cause damage to the corrugation of the jacket. **Pull R-flex by grabbing the carrier pipes – never pull the jacket.**

When uncoiling the pipe, please take care to ensure the pipe is not dragged along the ground. Doing so can cause the R-flex to be damaged by sharp objects. It is important to maintain control of the ends of each R-flex coil to prevent pipe ends from whipping back when untying the textile straps. The bending radii (see product data sheet) must not fall below the prescribed minimum during installation or when positioning the pipeline. Pipes must be laid in a serpentine course and may be covered with sand at regular intervals to prevent unwanted movement. General guidelines for laying underground pipes must be followed.

When laying larger dimensions and lengths, pulling devices such as winches or tail-end rollers may be used. Always connect these devices to the carrier pipe.

The carrier pipe ships from the factory with fitted protective end caps to prevent the entry of dirt and debris into the R-flex. Do not remove these caps until ready to connect the R-flex to a fixed connection.

Since the R-flex pipe is laid in a serpentine pattern, it is necessary to design for more pipe length than the measured trench length.

backfill has been brought to about 20" (50 cm) above the top of the pipe, a vibrating tamper may be used to compact the remainder of the soil. Do not use a backhoe or other mechanical device to fill the first layer of the trench as damage to the R-flex may occur.

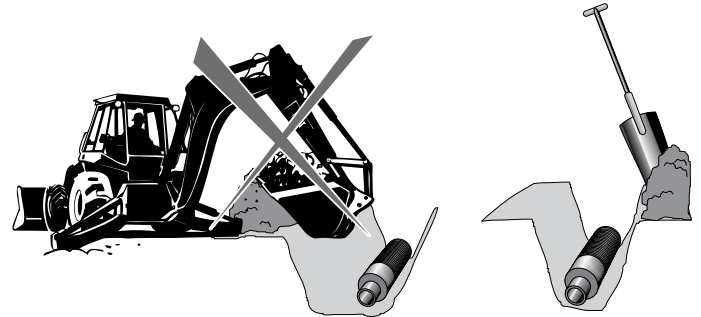

Transitions

When transitioning R-flex across a structural wall, be sure to keep the Dual pipe oriented in the vertical plane, as shown. Failure to do this will cause connection issues at necessary intersections.

The point where the R-flex penetrates the structure must be sealed. This can be done in a variety of ways, depending on the wall construction.

Backfilling Guidelines

Carefully place the R-flex pipeline on a compacted 4.0" (10 cm) bed of sand on the bottom of the trench. The quality of this sand bed providing uniform support for the pipe line has a decisive influence on the compressive stress of the system. Make sure that the pipes are fully covered with sand (granularity of 0-3mm).



Backfilling should be in layers of about 8.0" (20 cm) and compacted by hand. Care should be taken to remove any sharp objects from the backfill material. When the backfill has been brought to about 20.0" (50 cm) above the top of the pipe, a vibrating tamper may be used to compact the remainder of the soil. There should also be a warning tape bearing the legend "water pipe" laid directly above the pipe.

Once the trenches are excavated, the first layer of backfill should be carefully compacted with a shovel. When the

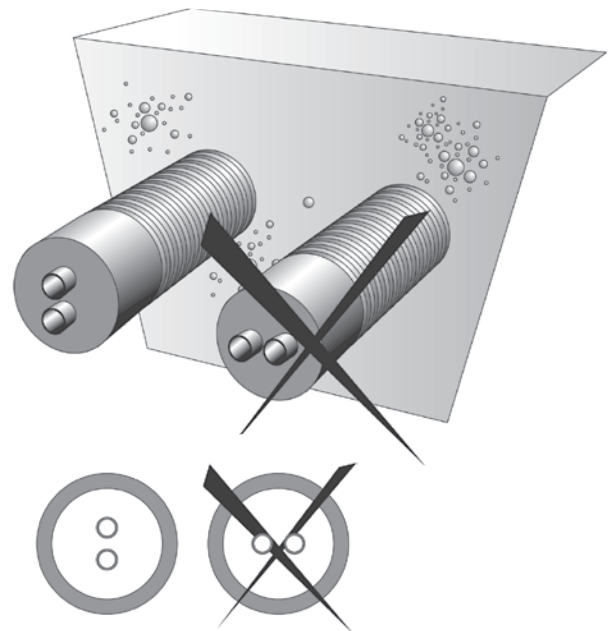

Wall seals are available in two styles: a Link Sleeve, and a Wall Sleeve. The Link Sleeve is designed to be used when transverse existing walls. The Wall Sleeve is to be used when a concrete wall is to be poured around the R-flex.

Link Sleeves

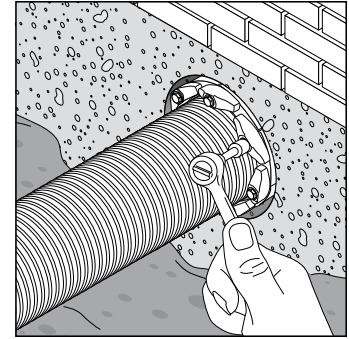
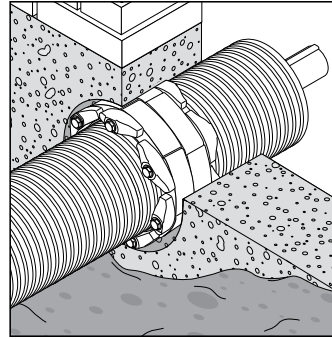
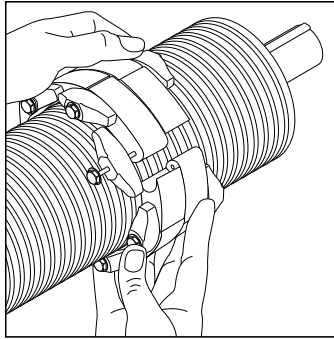
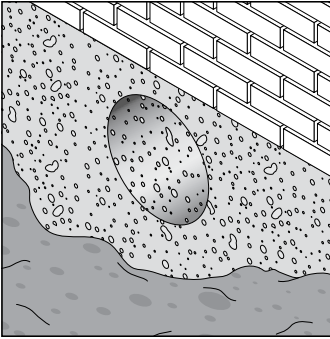

1. Drill a hole according to minimum and maximum dimensions (see column wall opening).

Center the pipe, cable or conduit in wall opening or casing. Make sure the pipe will be adequately supported on both ends.

2. Loosen rear pressure plate with nut just enough so links move freely. Check to be sure all bolt heads are facing the installer. Extra slack or sag is normal.

Make sure the pipe is held straight for at least 2 ft (60 cm) before and after the belt. Bends are not allowed.

3. Slide belt assembly into annular space. Start inserting Link-Seal modular seal assembly at the 6 o'clock position and work both sides up toward the 12 o'clock position

4. Using a hand socket or offset wrench ONLY, start at 12 o'clock. Do not tighten any bolt more than 4 turns at a time. Continue in a clockwise manner until links have been uniformly compressed. (Approx. 2 or 3 rotations)
5. Make 2 or 3 more passes at 4 turns per bolt MAXIMUM, tightening all bolts clockwise until all sealing elements "bulge" around all pressure plates.

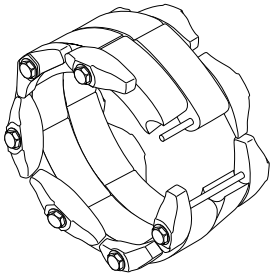

Link Belt	Description	Links Req'd	outer jacket Ø	wall opening
Order #				
81012948	LinkBelt, 125mm outer casing	15	125 mm	152 mm (6.00 in)
81012949	LinkBelt, 160mm outer casing	15	160 mm	203.3 mm (8.00 in)
81012950	LinkBelt, 200mm outer casing	17	200 mm	254 mm (10.00 in)

Link-Seal® Modular Seal - Do's

1. Make sure pipe is centered.
2. Install the belt with the pressure plates evenly spaced.
3. Make sure seal assembly and pipe surfaces are free from dirt.
4. For tight fits, use non-polluting liquid detergent to assist installation.

Link-Seal® Modular Seal - Don'ts

1. Don't install the belt with the pressure plates aimed in irregular directions. (Staggered)
2. Don't torque each bolt completely before moving on to the next.
3. Don't use high speed power tools (450 rpm or more)
4. Don't use grease installing Link-Seal modular seals.

R-flex™ insulated piping system

Wall Sleeves

Where pipes must pass through walls and floors of new structures, molded nonmetallic high density polyethylene CS sleeves can be installed.

Molded-in waterstop and reinforcing ribs serve to anchor the sleeve in the wall and resist pour forces. Nailer end caps are provided to make placement in forms simple and accurate. In the event of a field change they can be shortened with ordinary hand tools.

The sleeve is purposely molded with a texture on the outside surface to assure a much better bond than most plastic-to-concrete interfaces.

Each Wall Sleeve comes complete with corresponding sizes LinkBelts to complete the seal between the R-flex and the Wall Sleeve.

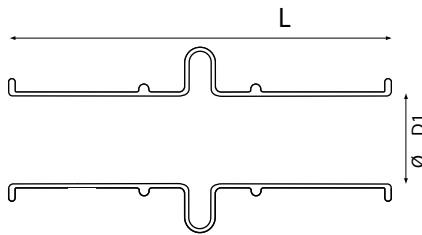
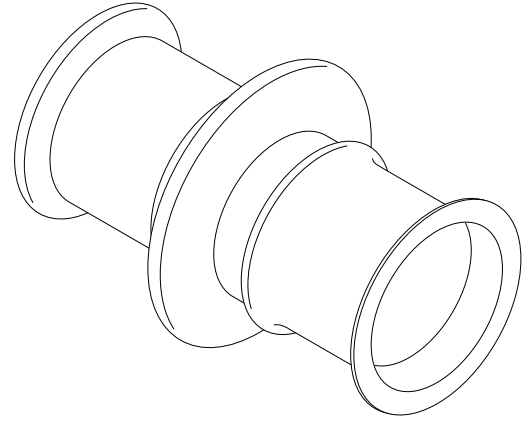

R-flex Wall sleeve

Order #	Ø pipe jacket	D1	L
81012931	125 mm (4.92 in)	208.5 mm (8.21 in)	406.4 mm (16 in)
81012932	160 mm (6.30 in)	208.5 mm (8.21 in)	406.4 mm (16 in)
81012933	200 mm (7.87 in)	258.8 mm (10.19 in)	406.4 mm (16 in)

Wall Sleeves come complete with end caps and corresponding Link Belts.

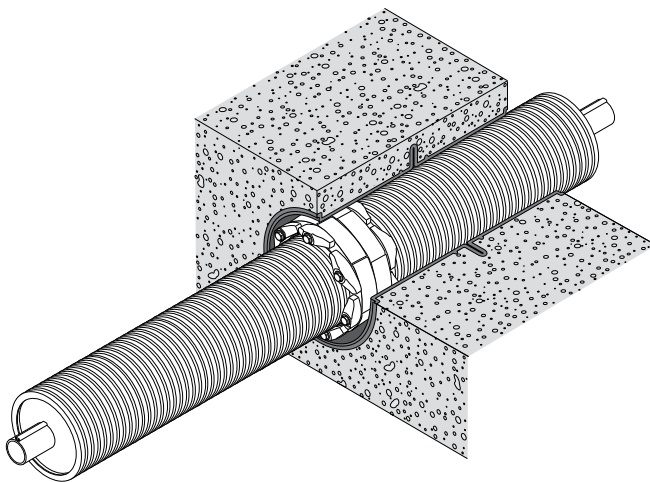

- 1 Nailer end caps are installed at each end of the sleeve to prevent deformation during the initial concrete pour and hold sleeve in exact location. Place one end cap at each end of the sleeve.
- 2 Remaining end cap is inserted into sleeve. Wide flange area on cap provides good surface against wall form, and resists weight of concrete pour.
- 3 Workman checks sleeve installation prior to erecting outside form wall.
- 4 Keep end caps in place after wall is poured and the form has been removed. The end caps seal sleeve against dirt and debris.
- 5 Just before pipe penetration, caps are removed to reveal clean inside surface of sleeve.

On the interior side of the wall, secure an "L" bracket to the wall to support the R-flex as it transitions through the wall. Install either a dust cap or a shrinkable end cap to the protruding end of the R-flex to keep dirt, debris, and possibly water from entering the inner casing. Do this before installing any connections or fittings.

R-flex must be supported at transition points to hard piping in the structure. Failure to do so may void the warranty. There can be significant expansion and contraction movement of the PEX carrier pipe which may cause connection leaks and/or damage to hard piping. R-flex can not be run internally (run inside the building). Transition from R-flex to a suitable carrier pipe rated for interior applications.



Non waterproof dust caps

Waterproof shrink caps.

Guidelines for installing shrinkable end caps.

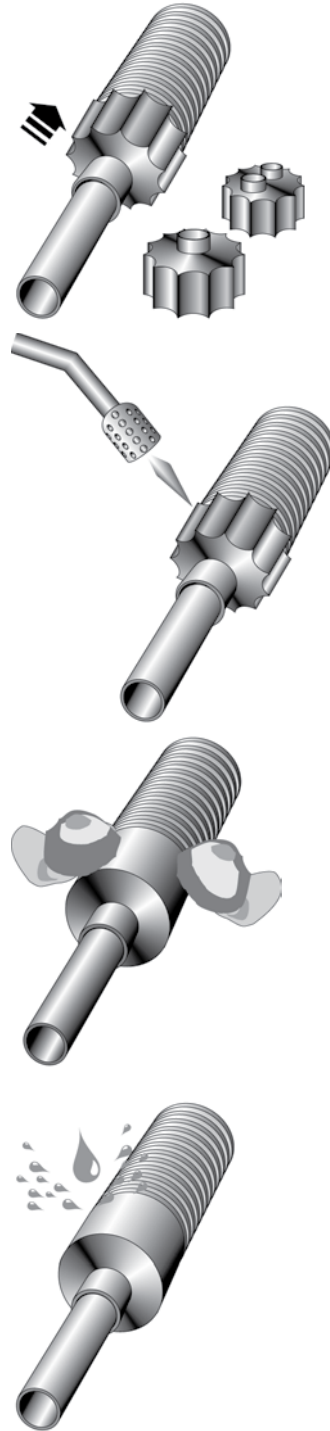

- 1 Slide the cap over the carrier pipe and the jacket.
- 2 Use a heat gun or mini torch with soft yellow flame (**DO NOT use a blue flame!**) to gently shrink the cap. Extra care should be taken not to damage the outer jacket.
- 3 Press the cap, wearing protective gloves.
- 4 The tail end of the pipe is now sealed watertight.

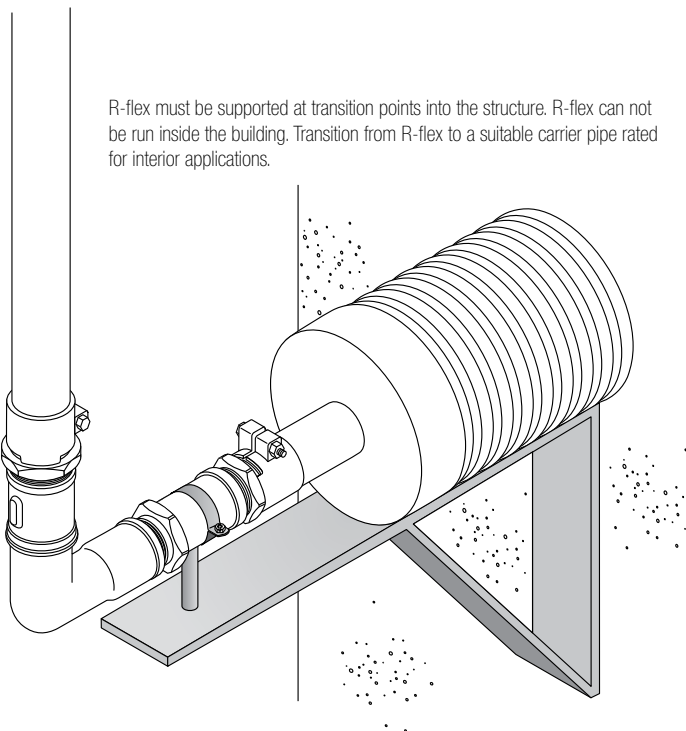

R-flex must be supported at transition points into the structure. R-flex can not be run inside the building. Transition from R-flex to a suitable carrier pipe rated for interior applications.

⚠ WARNING
 Keep hands away from any open flame. Do not touch – surface of shrink-wrap will be hot. Wear gloves when handling.

Intersections

Intersections generally consist of (1) branch tees, (2) elbows, or (3) mid-run couplings used to extend a run of R-flex. Each of these connections need to be encased in a connection casing - a waterproof protective shell.

1



2



3



When creating an intersection, make sure to follow these guidelines fully in order to maintain the warranty.

Keep R-flex Dual systems oriented in the vertical plane, as illustrated below. This will allow for proper assembly of the internal connections. This is especially critical when installing Tee intersections.

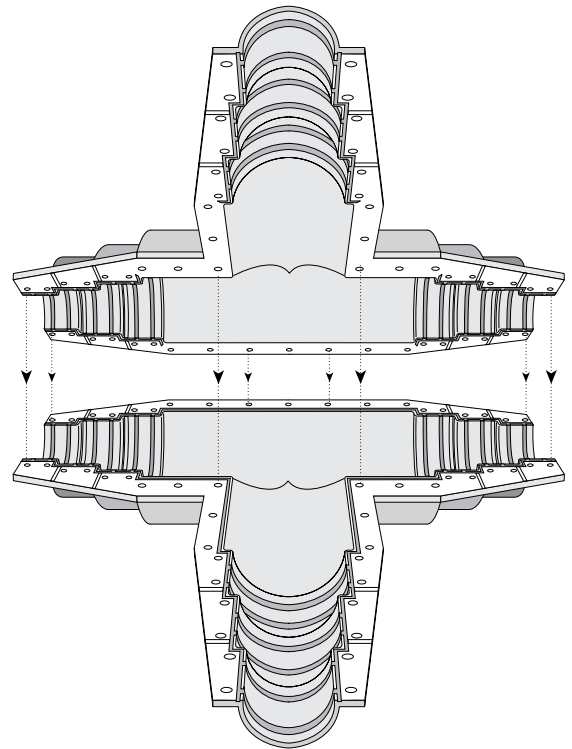
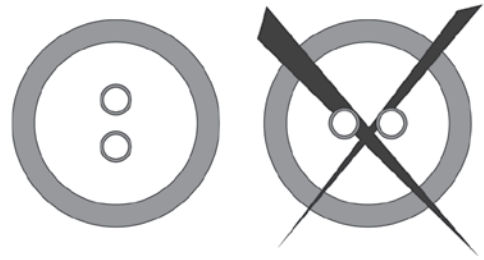

Casings provide additional insulation and seal outer jacket where field connections are made. The set comes with stone wool (insulation), a ready to use bitumen rubber kit, stainless steel bolts and an instruction leaflet. Heat shrinkable caps to be ordered separately.

Make sure the area where casings are to be installed is square with the R-flex entering and exiting the casing. Failure to do so will cause complications later when trying to assemble the upper half of the casing, and may create an improper seal at the transition points.

Holes in both shell-shaped casings (top and bottom) are identical and are pre-drilled allowing for quick, easy installation.

R-flex™ insulated piping system

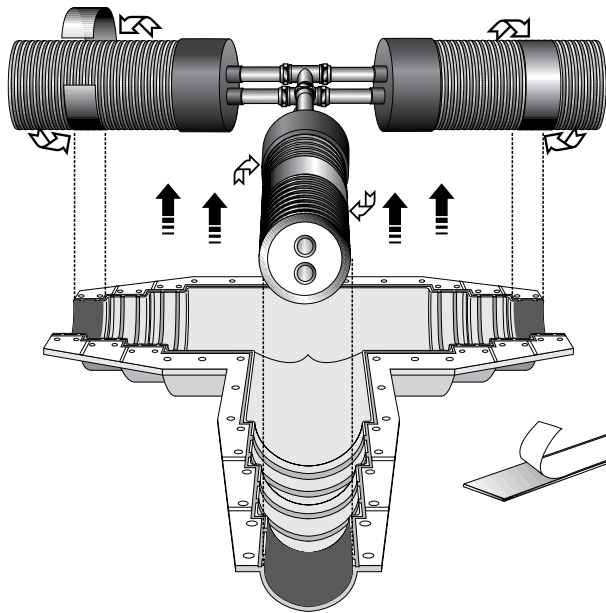

Each casing kit comes with bitumen strips (2 with couplings and elbows, 3 with tees) and an insulation blanket. Cut the strips to fit the pipe size. Do not cut the strips so they overlap as an improper fit will result at the entry point.

Remove the protective layer and fit the bitumen strips to the outside of the R-flex jacket and inside of the insulation casings at the (2 or 3) pipe entry points.

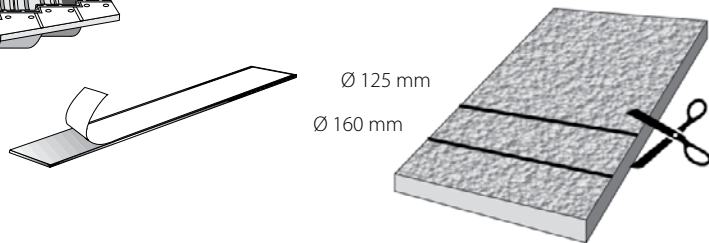

It is not necessary to cut for 200 mm

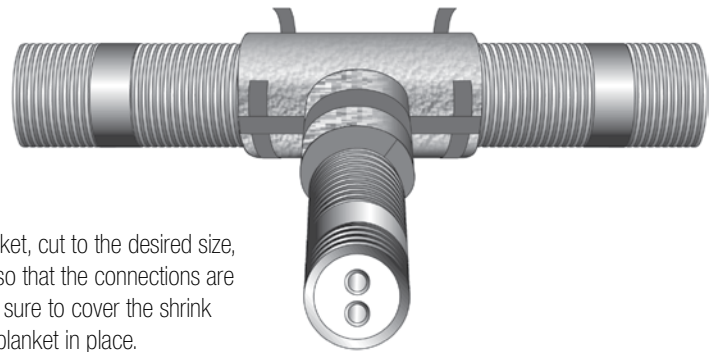
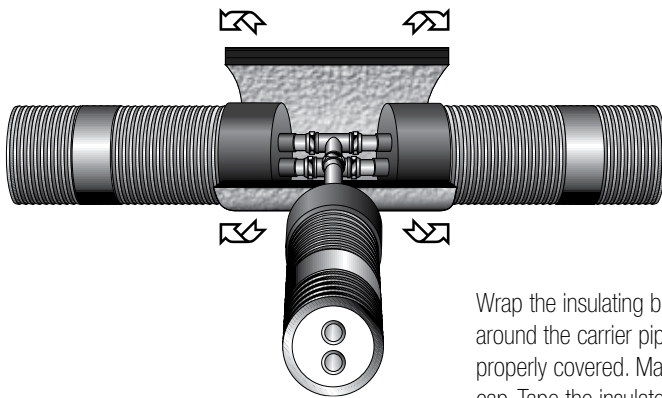

Wrap the insulating blanket, cut to the desired size, around the carrier pipe so that the connections are properly covered. Make sure to cover the shrink cap. Tape the insulated blanket in place.

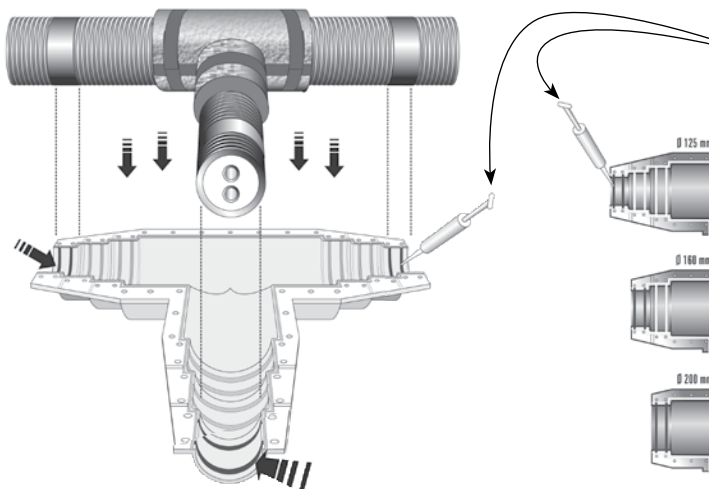

Apply a uniform bead of sealant to the grooves of both the upper and lower shell casings. Keep the bead to a thickness of about 5/32" (4 mm) to 3/16" (5 mm wide).

Insert the R-flex into the lower casing.

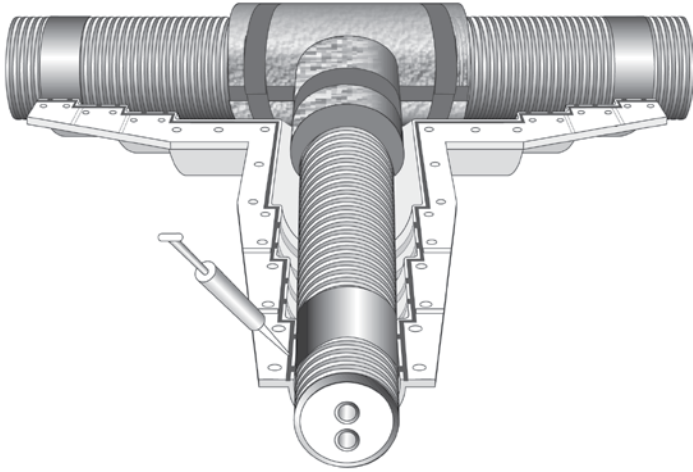

Apply sealant at a uniform rate along flanges of top and bottom casing (next to the drilled holes) to yield a thickness of about 1/4" (6 mm).

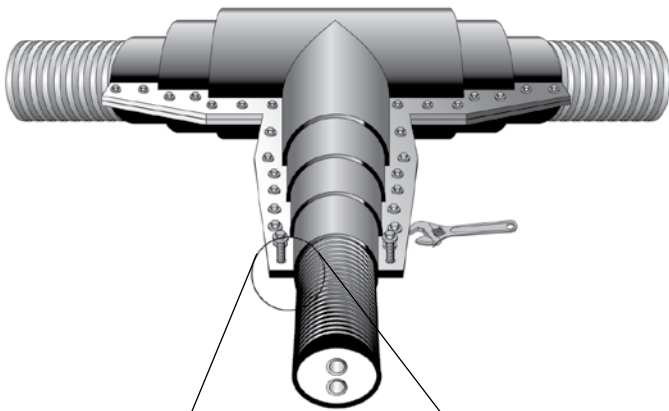

Carefully align the two casing halves and insert the stainless steel bolts. Tighten the stainless bolts.

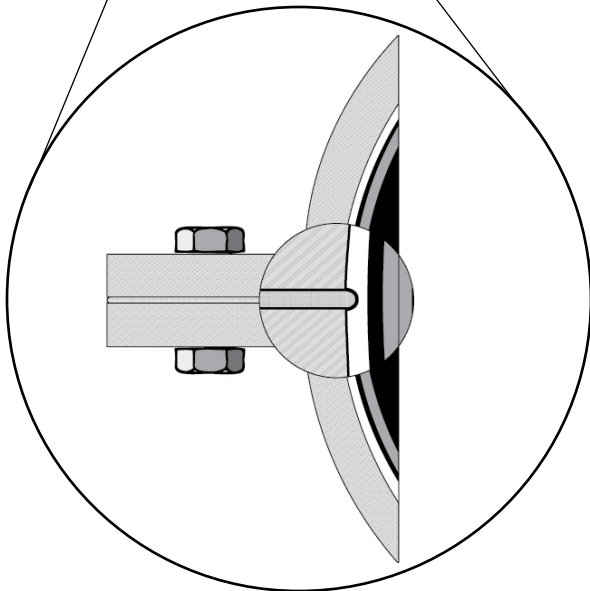

Check that the sealant is being squeezed through the side of the casing. This will indicate proper distribution of the sealant across the casing flange.

Inspection Chamber

Inspection chambers allow access to connections and valves after R-flex is installed and can be used as an alternative to the individual connection casings. Each chamber is equipped with 6 marked entries that can be cut to suit various opening sizes (125, 160 or 200 mm).

Each inspection chamber comes with a top lid, stainless bolts, and an instruction sheet.

The following steps will lead to establishing a waterproof connection.

Installation

Entries are marked and are to be cut off to suit the desired opening sizes. Carefully lower the inspection chamber on a level bed of sand, free of sharp objects.

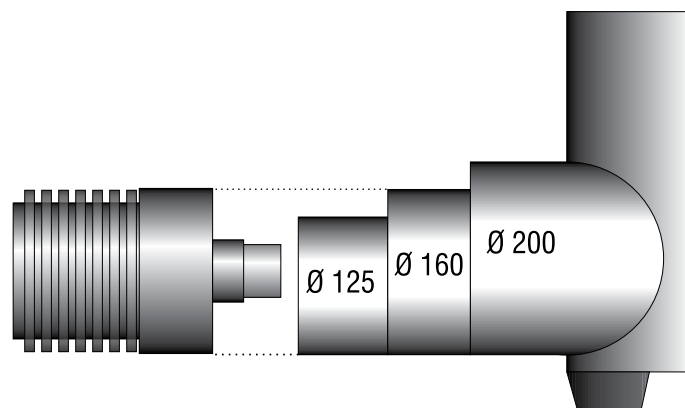
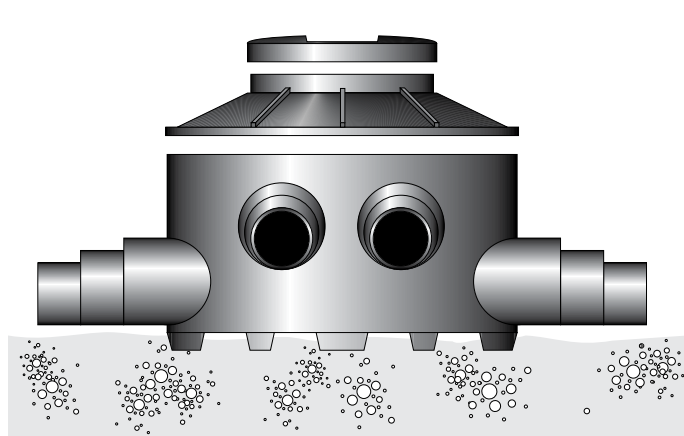
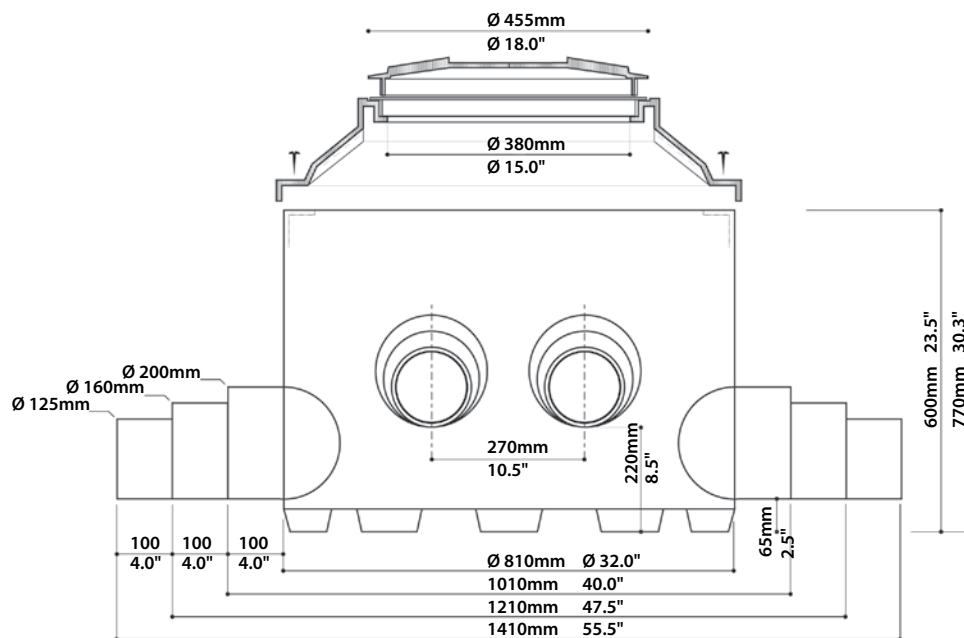

Connections

Before connecting the R-flex in the inspection chamber, slide a shrink cap (1) over the jacket and the carrier pipe. Use a heat gun (2) or mini torch with soft yellow flame (**do NOT use a blue flame!**) to gently shrink the cap. Further information on applying the shrink caps can be found in the section **Guidelines for installing shrinkable end caps**.

The use of the shrink cap is mandatory for any casing installation.

Slide a shrink sleeve (3) over the jacket, prior to pushing (4) the R-flex pipe into the inspection chamber.

Make all necessary connections in the chamber.

Slide the shrink sleeve back over the edge of the inspection chamber (5) so it covers both the chamber and the R-flex outer jacket. Gently shrink the sleeve onto the jacket, using a heat gun or a mini torch to ensure a waterproof connection between jacket and inspection chamber.

The use of the shrink sleeve is mandatory for any casing installation.

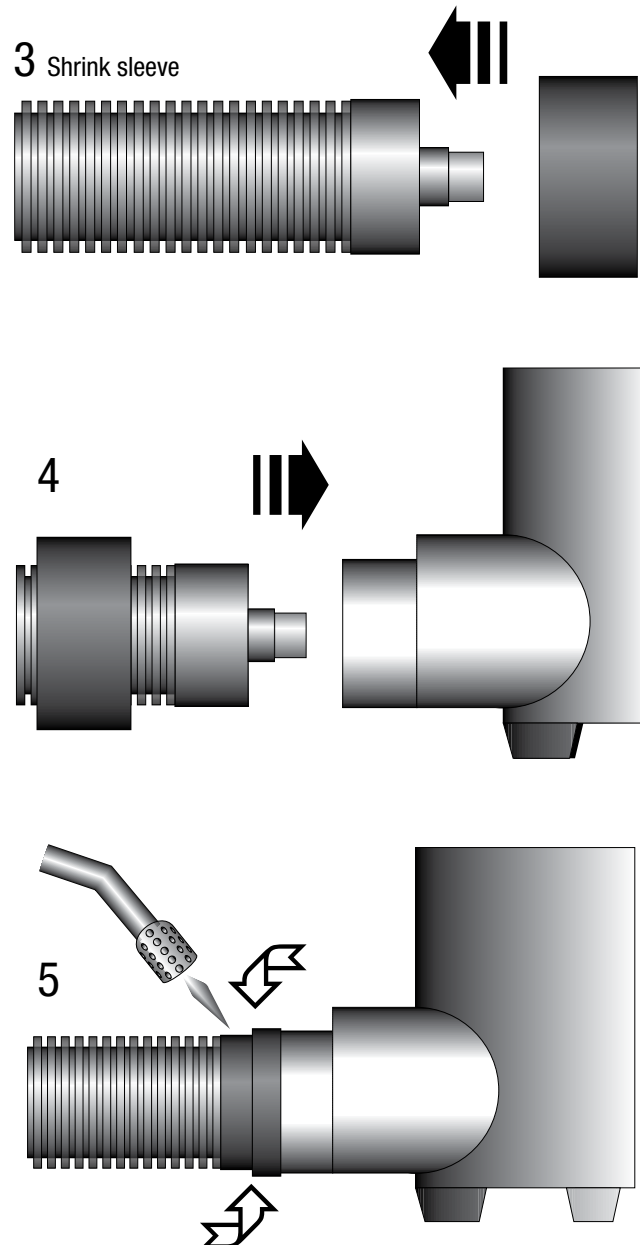
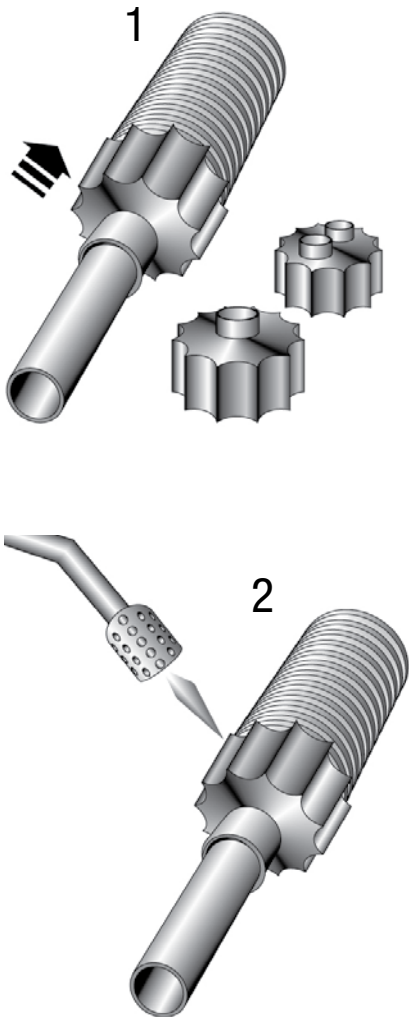

⚠ WARNING

Keep hands away from any open flame. Do not touch – surface of shrink wrap will be hot. Wear gloves when handling.

Branching possibilities

The inspection chamber, made of shock-resistant polyethylene, is very solid. It offers the possibility of:

- branching from Single to Dual R-flex pipes

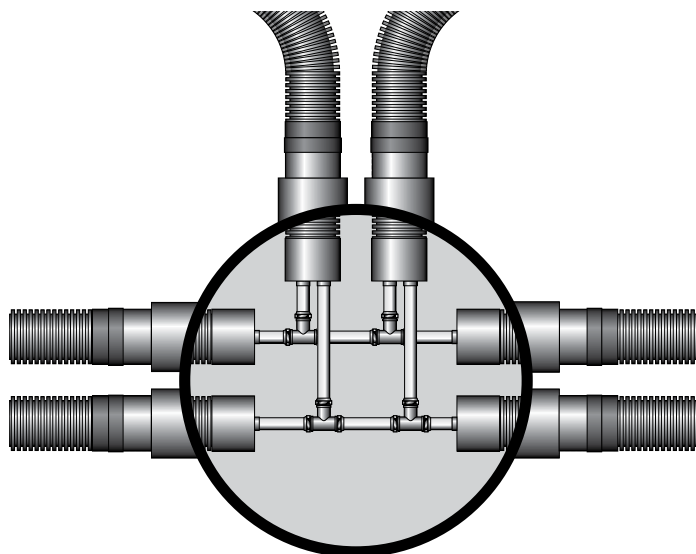

- branching from Dual to Dual R-flex pipes
- branching of several Dual pipes having various diameters

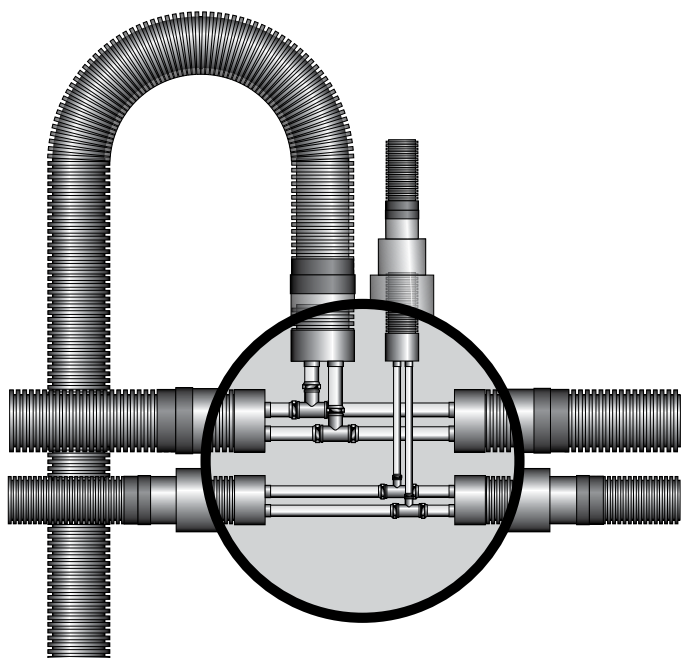

Sealing of inspection chamber

Apply sealant at a uniform rate, to edge of chamber body part to yield a thickness of about 0.4" x 0.4" (10 mm by 10 mm wide).

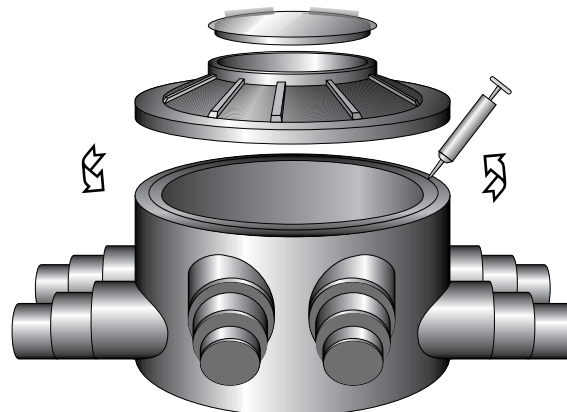

Place the pitched top on the body part.

Install the 6 stainless screws.

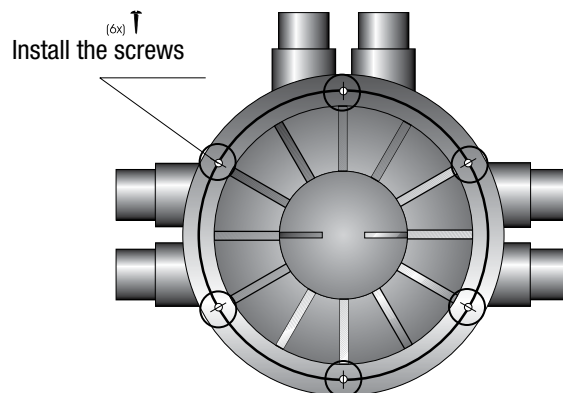

Carefully turn the lid clockwise to lock it. Do not damage the black gasket between body and top part.

Do not use excessive force.

Covering

The type of surface loading expected over the inspection chamber and R-flex pipe will determine the necessary installation depth. Refer to section **Backfilling Guidelines** for further information on depth and covering requirements. Check local codes to determine minimum pipe depth with relation to surface loads. Local codes may require different depths than those illustrated in this manual.

The inspection chamber needs to be positioned to allow the R-flex to enter the chamber without stress or bending. This may result in the chamber being below grade.

Always consider where the frost line is when determining trench depth. R-flex should always be installed below frost line.

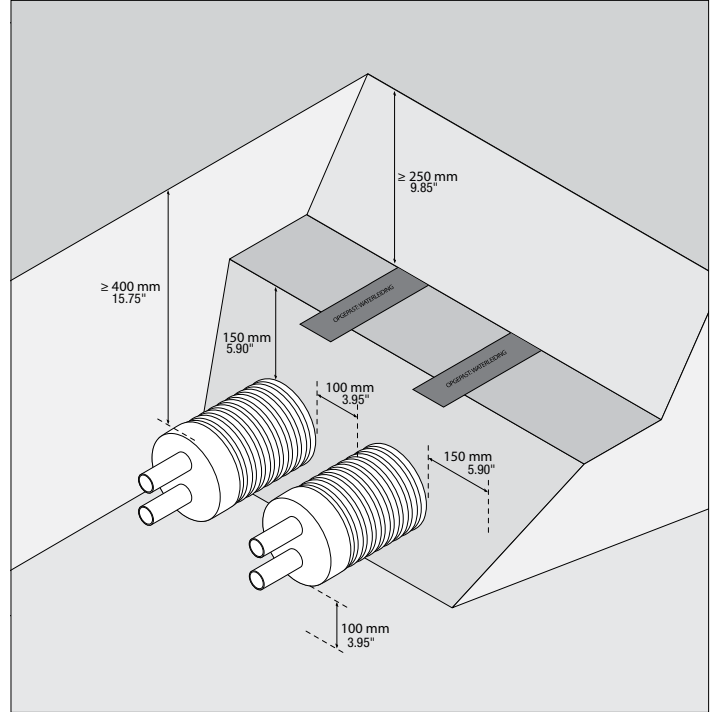

Check local code to determine minimum pipe depth with relation to surface loads.

Covering of the inspection chamber

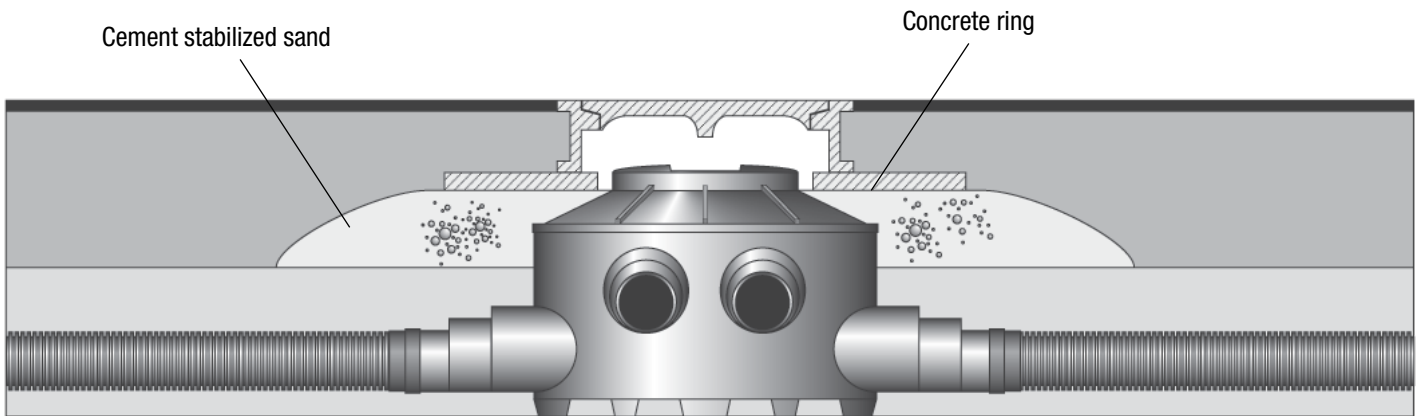

Outer Jacket Repairs

For Repairs Using Shrink Sleeve

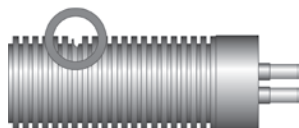

Locate damaged area.

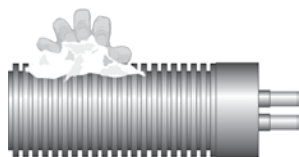

Make sure the jacket of the pipe is dry and clean.

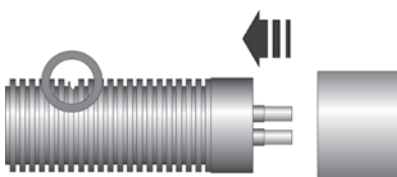

Slide the shrink sleeve over the damaged R-flex pipe.
NEVER CUT THE SLEEVE LENGTHWISE!

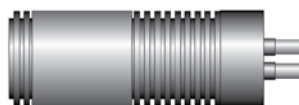

Use a heat gun or mini torch with soft yellow flame (**do NOT use a blue flame!**) to **gently** shrink the repair sleeve.

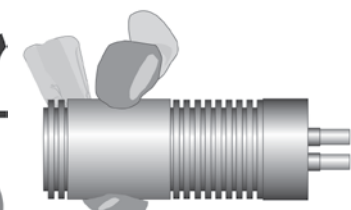

Press the sleeve, wearing protective gloves.

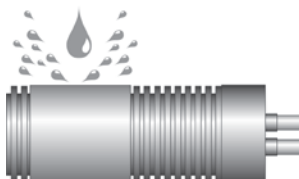

The damaged jacket is now sealed watertight.

For Repairs Using Shrink Tape

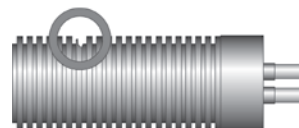

Locate damaged area.

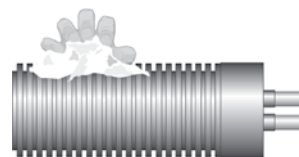

Make sure the jacket of the pipe is dry and clean.

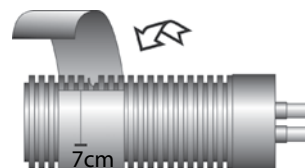

Wrap the repair tape around the damaged jacket, overlapping each preceding layer by about 7 cm (2.75").

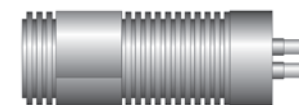

Use a heat gun or mini torch with soft yellow flame (**do NOT use a blue flame!**) to **gently** shrink the repair sleeve.

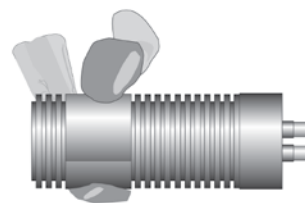

Press the sleeve, wearing protective gloves.

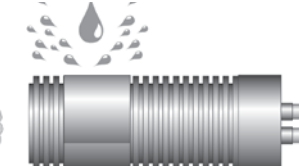

The damaged jacket is now sealed watertight.

⚠ WARNING

Keep hands away from any open flame. Do not touch – surface of shrink wrap will be hot. Wear gloves when handling.

Appendix A system design

R-flex U.S. equivalents

	Metric	25 mm	32 mm	40 mm	50 mm	63 mm	75 mm	90 mm	110 mm
	US Equivalent	1"	1-1/4"	1-1/2"	2"	2-1/2"	3"	3-1/2"	4"
Single	160 mm			81012929	81012886	81012887			
	200 mm						81012889	81012890	81012891
Dual	125 mm	81012879	81012880						
	160 mm			81012882					
	200 mm				81012884	81012885			

Required calculation steps:

1. Select the right pipe diameter:
 - Calculate the heat transfer.
 - Select the (carrier) pipe dimension for which the flow velocity does not exceed 7 ft/sec.
 - Choose either Single or Dual pipe system.
2. Determine the total physical pipe length:
 - Split the pipe length into straight and angled segments.
 - Calculate the equivalent length of the angled segments (as a function of the tightest suitable bends achievable with the specific pipe dimension).
 - After the length of all segments have been determined, simply add them all together and add 5%.

Rule of Thumb

To accommodate for the thermal expansion forces and minimize the forces on the fittings:

- A 5% add-on on the total length is required
- To be distributed over the total length (serpentine)

Bending angle into equivalent length:

$$L = a/180 \times \pi \times (R + d/2)$$

a = the angle of the bend from its center

R = bending radius based on the inside radius

d = outer diameter HDPE-outer jacket

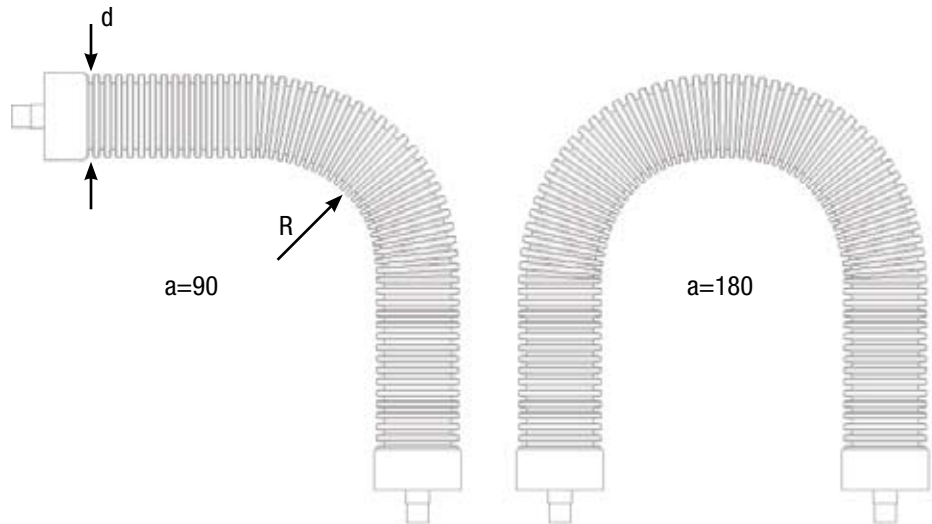

Example 45° turn:

$$L = 45/180 \times 3.14 \times (12 + 8/2)$$

$$L = 12.5 \text{ inches}$$

$$L = 1.05 \text{ ft}$$

Example 90° turn:

$$L = 90/180 \times 3.14 \times (12 + 8/2)$$

$$L = 25.13 \text{ inches}$$

$$L = 2.09 \text{ ft}$$

Example 180° turn:

$$L = 180/180 \times 3.14 \times (12 + 8/2)$$

$$L = 50.27 \text{ inches}$$

$$L = 4.19 \text{ ft}$$

	Description	Jacket OD	Bend Radius	45° Bend	90° Bend
Single	160/40	160 mm (6.3 in)	350 mm (13.8 in)	305 mm (1.00 ft.)	610 mm (2.00 ft)
	160/50		450 mm (17.8 in)	433 mm (1.42 ft.)	866 mm (2.84 ft)
	160/63		550 mm (21.7 in)		
	200/75	200 mm (7.9 in)	800 mm (31.5 in)	485 mm (1.59 ft.)	969 mm (3.18 ft)
	200/90		1100 mm (43.4 in)	491 mm (1.61 ft.)	981 mm (3.22 ft)
	200/110		1200 mm (47.3 in)	539 mm (1.77 ft.)	1079 mm (3.54 ft)
Dual	125/2x1"	4.9 in (125 mm)	11.8" (300 mm)	0.85 ft (259 mm)	1.7 ft (518 mm)
	125/2x32	125 mm (4.9 in)	300 mm (11.8 in)	259 mm (0.85 ft.)	518 mm (1.7 ft)
	160/2x40	160 mm (6.3 in)	600 mm (23.7 in)	512 mm (1.66 ft.)	1024 mm (3.36 ft)
	200/2x50	200 mm (7.9 in)	800 mm (31.5 in)	639 mm (2.10 ft.)	1278 mm (4.19 ft)
	200/2x63		1200 mm (47.3 in)	850 mm (2.79 ft.)	1700 mm (5.58 ft)

3. Calculate the heat load at the source
(as a function of the target heat capacity at recipient side)

Determine heat transfer losses:

- Calculate ΔT as the temperature differential between the surrounding soil temperature and the temperature in the carrier pipe(s).
- Locate this ΔT along the X axis of the corresponding graph
- Read the heat loss at the corresponding coordinate.
- Multiply the heat loss per unit with the total pipe length to obtain the total transfer losses.

Heat load at source = required capacity + transfer losses

Rule of Thumb

Ground temperature: for planning purposes a ground temperature of about 50°F (10°C) is a realistic assumption [minimum laying depth of 2.0 ft (600 mm) to 3.2 ft (1000 mm)]

4. Determine pressure loss in the system

Calculate the total equivalent length of the system, by including the length equivalent of all brass fittings

Use the "Pressure Loss Table" to determine the pressure loss per 100 feet of Single R-flex or per 50 feet of Dual R-flex.

Complete Pressure Loss Tables are found in the back of this Manual.

Single R-flex

Divide the total length (supply, return, bends, fittings, etc) by 100. Multiply this length of the system with the pressure drop per 100' found in the table to obtain the system's overall pressure loss (head loss).

Dual R-flex

Divide the total length (supply, return, bends, fittings, etc) by 50. Multiply this length of the system with the pressure drop per 50' found in the table to obtain the system's overall pressure loss (head loss).

Appendix A cont'd

Heat losses

The values used in calculating the heat loss are:

- Insulation 0.0365 W/m.K (0.0211 BTU/hr.sq.ft. °F)
- Ground 1.2 W/m.K (0.693 BTU/hr.sq.ft. °F)
- PEX pipe: 0.35 W/m.K (0.202 BTU/hr.sq.ft. °F)

Depth of cover over top of pipe: 50 cm (20")

With the ΔT being calculated, the heat loss per length of piping can easily be read along the corresponding line of the table.

For Dual

$$\Delta T = \frac{(T_v + T_r)}{2} - T_o$$

T_v : Fluid supply temperature
 T_r : Fluid return temperature
 T_o : Ground temperature

R-flex Dual

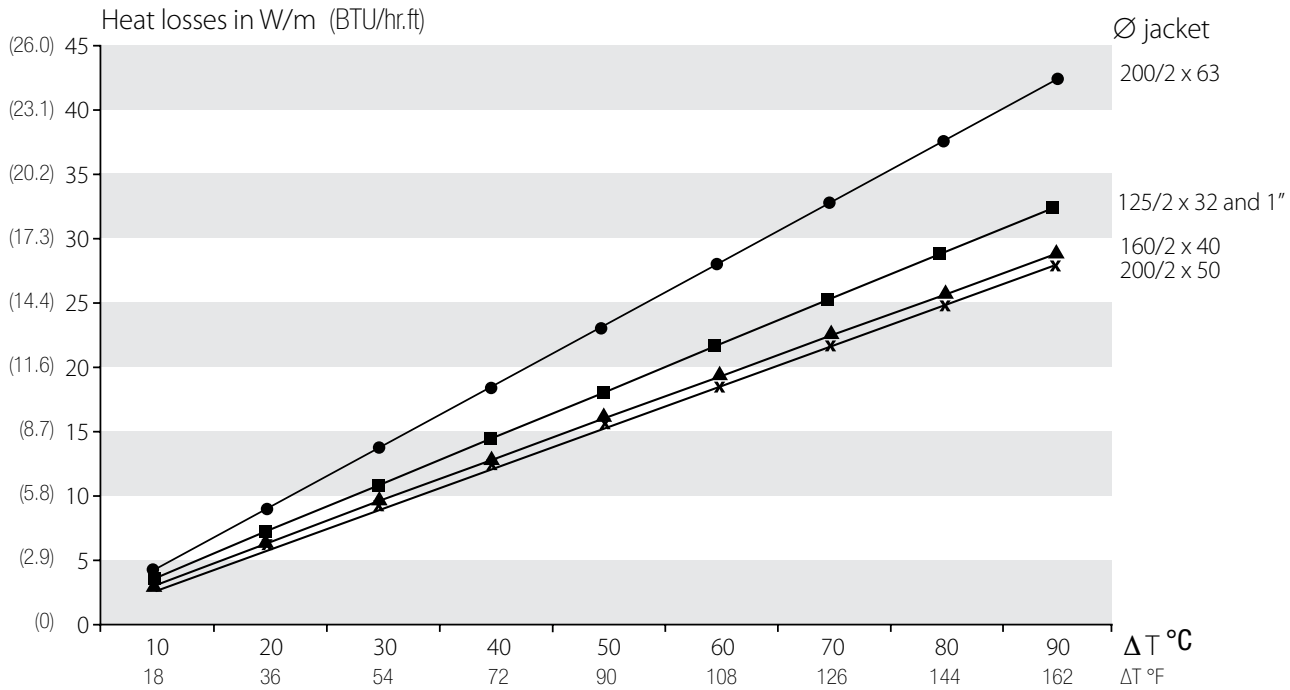

** May not currently be offered.

For Single
 $\Delta T = T_v - T_o$
 T_v : Fluid supply temperature
 T_o : Ground temperature

R-flex Single

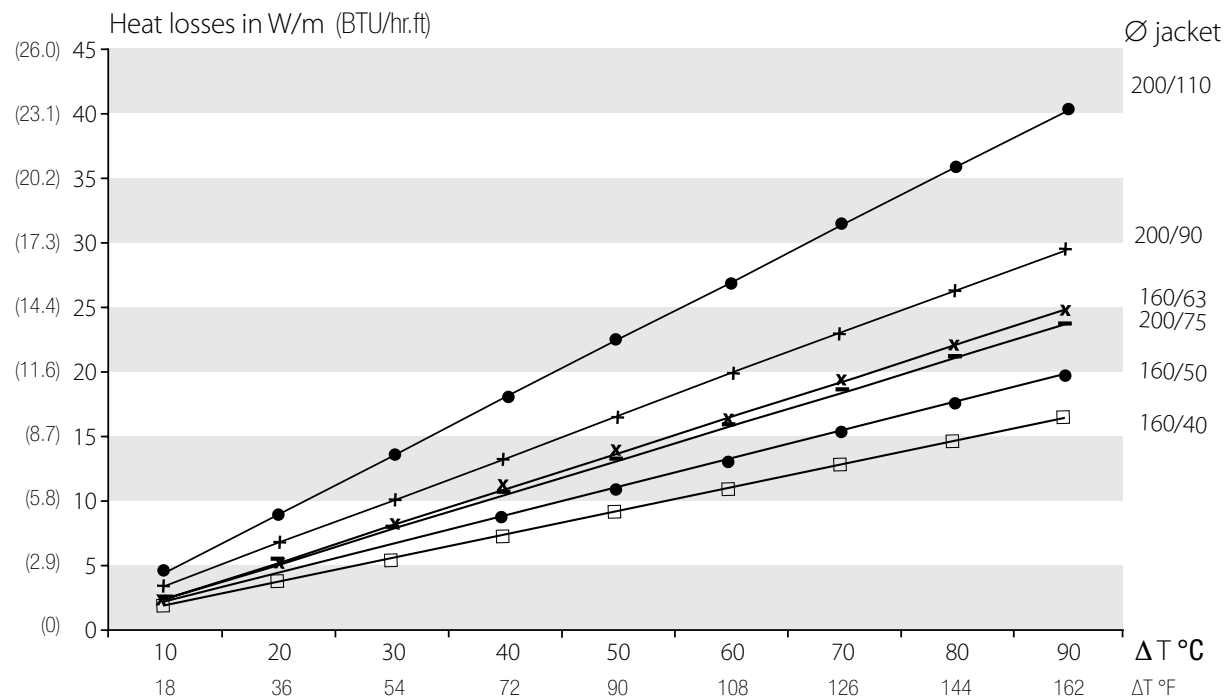

Appendix B pressure drop charts

Pressure Drop Methodology

Calculating pressure drop through a tube or circuit is dependent on a wide range of factors – viscosity, density, flow rate, and tube conditions.

Pressure drop (loss) in the circuits is determined using the Darcy-Weisback equation. These equations are referenced in ASHRAE's 2005 Handbook - Fundamentals, section 2.0, equations 5, 18, 30, 32a, 32b, and 32c.

Glycol values referenced are based on DowFrost™ Technical Specification (form no. 180-01272-402AMS). Different glycol concentrations, types, and formats will result in different pressure drop calculations. The data points provided should only be used as a reference point.

Data

DowFrost™ 50% Solution (extrapolated data)				Water			
°F	Density (lbs/cu.ft.)	Dynamic Viscosity (cps)*	Dynamic Viscosity (lb/ft-s)	°F	Density (lbs/cu.ft.)	Dynamic Viscosity (cps)	Dynamic Viscosity (lb-ft-s)
40	65.670	14.280	0.0096	80	62.22	0.858	0.00058
60	65.210	12.394	0.0048	100	61.99	0.681	0.00046
80	64.750	10.509	0.0029	120	61.71	0.557	0.00037
100	64.290	8.623	0.0020	140	61.38	0.466	0.00031
120	63.830	6.737	0.0014	160	61.00	0.398	0.00027
140	63.370	4.851	0.0011	180	60.58	0.345	0.00023
160	62.910	2.966	0.0009				
180	62.450	1.080	0.0007				

* derived equation used for extrapolation: $y = 8473.8x^{(-1.7307)}$

The table shown assume an approximate mixture of water/glycol of 50% concentration. Actual pressure drop values will change depending on actual concentrations and fluid temperature.

Calculations

Where:

- HL = Head Loss in feet per 100 feet of pipe
- f = Friction factor
- L = Length of pipe (ft)
- V = Fluid velocity (ft/sec)
- d = Pipe inside diameter (ft)
- g = Gravity (32.2 ft/sec²)
- Re = Reynold's number
- e = Pipe roughness factor (est. 3.0E-6)

$$HL = f \left[\frac{LV^2}{d2g} \right]$$

$$f = 8 \left[\left(\frac{8}{Re} \right)^{12} + \left(\frac{1}{(A+B)^{1.5}} \right) \right]^{1/12}$$

$$A = \left[2.457 \ln \left(\frac{1}{(7/Re)^{0.9} + (0.27e/d)} \right) \right]^{16}$$

$$B = \left(\frac{37,530}{Re} \right)^{16}$$

50 mm R-flex Single, Pressure Drop per 100' (1.79" Nom. ID)															
°F	11.00 (1.78)	12.00 (1.94)	13.00 (2.11)	14.00 (2.27)	15.00 (2.43)	16.00 (2.59)	17.00 (2.75)	18.00 (2.92)	19.00 (3.08)	20.00 (3.24)	25.00 (4.05)	30.00 (4.86)	35.00 (5.67)	40.00 (6.48)	GPM (ft/sec)
80°	0.90	1.04	1.20	1.37	1.55	1.74	1.93	2.14	2.35	2.58	3.84	5.31	7.00	8.89	100% Water
	1.37	1.59	1.82	2.07	2.33	2.60	2.88	3.18	3.49	3.81	5.61	7.70	10.07	12.72	50% Water/Glycol
100°	0.85	0.99	1.14	1.30	1.47	1.65	1.84	2.03	2.24	2.45	3.65	5.07	6.68	8.50	100% Water
	1.23	1.43	1.64	1.86	2.09	2.34	2.60	2.87	3.15	3.45	5.08	6.99	9.17	11.59	50% Water/Glycol
120°	0.81	0.95	1.09	1.25	1.41	1.58	1.76	1.95	2.15	2.35	3.51	4.87	6.42	8.17	100% Water
	1.13	1.31	1.50	1.71	1.93	2.16	2.40	2.65	2.91	3.19	4.71	6.49	8.52	10.79	50% Water/Glycol
140°	0.78	0.91	1.05	1.20	1.36	1.52	1.70	1.88	2.07	2.27	3.39	4.70	6.21	7.91	100% Water
	1.05	1.22	1.41	1.60	1.81	2.02	2.25	2.48	2.73	2.99	4.43	6.11	8.03	10.18	50% Water/Glycol
160°	0.75	0.88	1.02	1.16	1.31	1.47	1.64	1.82	2.01	2.20	3.29	4.57	6.03	7.69	100% Water
	0.99	1.16	1.33	1.51	1.71	1.91	2.13	2.35	2.59	2.83	4.20	5.81	7.64	9.69	50% Water/Glycol
180°	0.73	0.86	0.99	1.13	1.28	1.43	1.60	1.77	1.95	2.14	3.20	4.45	5.88	7.50	100% Water
	0.95	1.10	1.27	1.45	1.63	1.83	2.04	2.25	2.48	2.72	4.03	5.58	7.34	9.32	50% Water/Glycol

63 mm R-flex Single, Pressure Drop per 100' (2.25" Nom. ID)														
°F	15.00 (1.53)	20.00 (2.04)	25.50 (2.55)	30.00 (3.08)	35.00 (3.57)	40.00 (4.08)	45.00 (4.59)	50.00 (5.10)	55.00 (5.61)	60.00 (6.13)	65.00 (6.64)	70.00 (7.15)	GPM (ft/sec)	
80°	0.52	0.86	1.27	1.76	2.31	2.94	3.63	4.38	5.20	6.08	7.02	8.02	100% Water	
	0.78	1.28	1.88	2.58	3.37	4.25	5.22	6.27	7.41	8.63	9.93	11.32	50% Water/Glycol	
100°	0.49	0.81	1.21	1.67	2.20	2.80	3.46	4.18	4.97	5.81	6.71	7.67	100% Water	
	0.70	1.15	1.70	2.34	3.06	3.86	4.75	5.72	6.76	7.88	9.08	10.36	50% Water/Glycol	
120°	0.47	0.78	1.16	1.61	2.12	2.69	3.33	4.02	4.78	5.59	6.46	7.39	100% Water	
	0.65	1.06	1.57	2.16	2.83	3.59	4.41	5.32	6.30	7.35	8.47	9.66	50% Water/Glycol	
140°	0.45	0.75	1.12	1.55	2.04	2.60	3.22	3.89	4.62	5.41	6.26	7.16	100% Water	
	0.60	1.00	1.47	2.03	2.67	3.38	4.16	5.02	5.94	6.94	8.00	9.13	50% Water/Glycol	
160°	0.43	0.73	1.08	1.50	1.98	2.52	3.12	3.78	4.49	5.26	6.09	6.97	100% Water	
	0.57	0.94	1.40	1.93	2.53	3.21	3.96	4.78	5.66	6.61	7.63	8.72	50% Water/Glycol	
180°	0.42	0.71	1.05	1.46	1.93	2.46	3.05	3.69	4.38	5.14	5.94	6.80	100% Water	
	0.54	0.90	1.34	1.85	2.43	3.08	3.80	4.59	5.45	6.37	7.35	8.39	50% Water/Glycol	

75 mm R-flex Single, Pressure Drop per 100' (2.69" Nom. ID)														
°F	30.00 (2.15)	35.00 (2.50)	40.00 (2.86)	45.00 (3.22)	50.00 (3.58)	55.00 (3.93)	60.00 (4.29)	65.00 (4.65)	70.00 (5.01)	75.00 (5.37)	80.00 (5.72)	85.00 (6.08)	90.00 (6.44)	GPM (ft/sec)
80°	0.75	0.99	1.25	1.55	1.87	2.21	2.59	2.99	3.41	3.86	4.34	4.84	5.37	100% Water
	1.11	1.45	1.83	2.25	2.70	3.18	3.71	4.27	4.86	5.48	6.14	6.83	7.55	50% Water/Glycol
100°	0.71	0.94	1.19	1.47	1.78	2.11	2.47	2.85	3.26	3.69	4.15	4.63	5.13	100% Water
	1.01	1.31	1.66	2.04	2.45	2.90	3.38	3.89	4.43	5.01	5.61	6.25	6.92	50% Water/Glycol
120°	0.68	0.90	1.15	1.42	1.71	2.03	2.38	2.75	3.14	3.56	4.00	4.46	4.95	100% Water
	0.93	1.22	1.54	1.89	2.28	2.70	3.14	3.62	4.13	4.67	5.25	5.83	6.46	50% Water/Glycol
140°	0.66	0.87	1.11	1.37	1.65	1.96	2.30	2.66	3.04	3.44	3.87	4.32	4.79	100% Water
	0.87	1.14	1.45	1.78	2.15	2.54	2.96	3.42	3.90	4.41	4.95	5.51	6.11	50% Water/Glycol
160°	0.64	0.84	1.07	1.33	1.61	1.91	2.23	2.58	2.95	3.35	3.76	4.20	4.66	100% Water
	0.83	1.08	1.37	1.69	2.04	2.42	2.82	3.26	3.72	4.20	4.72	5.26	5.83	50% Water/Glycol
180°	0.62	0.82	1.04	1.29	1.56	1.86	2.18	2.52	2.88	3.27	3.67	4.10	4.55	100% Water
	0.79	1.04	1.32	1.62	1.96	2.32	2.71	3.13	3.58	4.05	4.54	5.07	5.61	50% Water/Glycol

90 mm R-flex Single, Pressure Drop per 100' (3.22" Nom. ID)															
°F	50.00 (2.49)	55.00 (2.74)	60.00 (2.99)	65.00 (3.24)	70.00 (3.49)	75.00 (3.73)	80.00 (3.98)	85.00 (4.23)	90.00 (4.48)	100 (4.98)	110 (5.48)	120 (5.97)	130 (6.47)	140 (6.97)	GPM (ft/sec)
80°	0.78	0.93	1.09	1.25	1.43	1.62	1.82	2.03	2.25	2.71	3.22	3.77	4.36	4.98	100% Water
	1.14	1.35	1.57	1.80	2.05	2.32	2.59	2.88	3.19	3.84	4.54	5.29	6.09	6.94	50% Water/Glycol
100°	0.75	0.89	1.04	1.20	1.37	1.55	1.74	1.94	2.15	2.60	3.08	3.61	4.17	4.77	100% Water
	1.04	1.22	1.43	1.64	1.87	2.11	2.37	2.63	2.91	3.51	4.15	4.85	5.59	6.38	50% Water/Glycol
120°	0.72	0.85	0.99	1.15	1.31	1.49	1.67	1.86	2.07	2.50	2.97	3.48	4.02	4.60	100% Water
	0.96	1.14	1.32	1.53	1.74	1.97	2.20	2.45	2.72	3.27	3.88	4.53	5.23	5.96	50% Water/Glycol
140°	0.69	0.82	0.96	1.11	1.27	1.44	1.62	1.80	2.00	2.42	2.88	3.37	3.90	4.46	100% Water
	0.90	1.07	1.25	1.44	1.64	1.85	2.08	2.32	2.56	3.09	3.67	4.29	4.95	5.65	50% Water/Glycol
160°	0.67	0.80	0.93	1.08	1.23	1.40	1.57	1.75	1.94	2.35	2.80	3.28	3.80	4.35	100% Water
	0.86	1.02	1.19	1.37	1.56	1.77	1.98	2.21	2.44	2.95	3.50	4.09	4.73	5.40	50% Water/Glycol
180°	0.65	0.78	0.91	1.05	1.20	1.36	1.53	1.71	1.90	2.30	2.73	3.20	3.71	4.25	100% Water
	0.82	0.98	1.14	1.31	1.50	1.70	1.90	2.12	2.35	2.84	3.37	3.94	4.55	5.21	50% Water/Glycol

110 mm R-flex Single, Pressure Drop per 100' (3.94" Nom. ID)										
°F	90 (3.00)	100 (3.33)	110 (3.66)	120 (4.00)	130 (4.33)	140 (4.66)	150 (4.99)	175 (5.83)	200 (6.67)	GPM (ft/sec)
80°	0.86	1.03	1.23	1.43	1.66	1.89	2.14	2.83	3.61	100% Water
	1.23	1.47	1.74	2.03	2.34	2.66	3.01	3.95	5.00	50% Water/Glycol
100°	0.82	0.99	1.17	1.37	1.58	1.81	2.05	2.71	3.46	100% Water
	1.12	1.34	1.59	1.86	2.14	2.44	2.76	3.62	4.60	50% Water/Glycol
120°	0.78	0.95	1.13	1.32	1.53	1.74	1.98	2.62	3.34	100% Water
	1.04	1.25	1.48	1.73	2.00	2.28	2.57	3.39	4.31	50% Water/Glycol
140°	0.76	0.92	1.09	1.28	1.48	1.69	1.92	2.54	3.23	100% Water
	0.98	1.18	1.40	1.64	1.89	2.15	2.44	3.21	4.08	50% Water/Glycol
160°	0.74	0.89	1.06	1.24	1.44	1.64	1.86	2.47	3.15	100% Water
	0.93	1.13	1.33	1.56	1.80	2.06	2.33	3.07	3.90	50% Water/Glycol
180°	0.72	0.87	1.03	1.21	1.40	1.60	1.82	2.41	3.08	100% Water
	0.90	1.08	1.28	1.50	1.73	1.98	2.24	2.96	3.77	50% Water/Glycol

Pressure drop through R-flex fittings

Equivalent ft. R-flex	
Coupling	1.0
Elbow	5.0
Tee-Run	1.0
Tee-Branch	3.3

1" R-flex Dual, Pressure Drop per 50' (0.86" Nom. ID)																
°F	2.50 (1.36)	3.00 (1.64)	3.50 (1.91)	4.00 (2.18)	4.50 (2.46)	5.00 (2.73)	5.50 (3.00)	6.00 (3.28)	6.50 (3.55)	7.00 (3.82)	8.00 (4.37)	9.00 (4.91)	10.00 (5.46)	11.00 (6.01)	12.00 (6.55)	GPM (ft/sec)
80°	1.21	1.66	2.17	2.74	3.36	4.04	4.78	5.57	6.42	7.31	9.26	11.40	13.75	16.29	19.02	100% Water
	1.20	2.23	3.36	4.28	5.22	6.24	7.34	8.50	9.75	11.06	13.89	17.00	20.38	24.02	27.92	50% Water/Glycol
100°	1.14	1.56	2.05	2.29	3.18	3.83	4.53	5.28	6.08	6.94	8.79	10.84	13.08	15.51	18.11	100% Water
	1.71	2.34	3.04	3.81	4.66	5.57	6.56	7.61	8.74	9.92	12.50	15.32	18.39	21.71	25.26	50% Water/Glycol
120°	1.08	1.49	1.95	2.47	3.04	3.66	4.33	5.05	5.82	6.64	8.42	10.39	12.54	14.88	17.39	100% Water
	1.56	2.13	2.77	3.48	4.26	5.10	6.01	6.99	8.03	9.13	11.51	14.13	16.99	20.07	23.37	50% Water/Glycol
140°	1.04	1.43	1.87	2.37	2.92	3.51	4.16	4.86	5.60	6.39	8.11	10.02	12.10	14.36	16.79	100% Water
	1.45	1.97	2.57	3.23	3.96	4.75	5.61	6.52	7.50	8.53	10.77	13.24	15.93	18.83	21.95	50% Water/Glycol
160°	1.00	1.38	1.80	2.29	2.82	3.40	4.02	4.70	5.42	6.19	7.86	9.71	11.73	13.93	16.29	100% Water
	1.35	1.85	2.41	3.04	3.73	4.48	5.29	6.16	7.08	8.06	10.19	12.54	15.09	17.86	20.83	50% Water/Glycol
180°	0.97	1.33	1.75	2.22	2.73	3.30	3.91	4.56	5.27	6.01	7.64	9.44	11.42	13.56	15.87	100% Water
	1.29	1.76	2.30	2.90	3.56	4.28	5.06	5.89	6.78	7.72	9.76	12.02	14.48	17.14	20.00	50% Water/Glycol

32 mm R-flex Dual, Pressure Drop per 50' (1.15" Nom. ID)																
°F	5.00 (1.96)	5.50 (2.16)	6.00 (2.36)	6.50 (2.55)	7.00 (2.75)	8.00 (3.14)	9.00 (3.54)	10.00 (3.93)	11.00 (4.32)	12.00 (4.71)	13.00 (5.11)	14.00 (5.50)	15.00 (5.89)	16.00 (6.29)	17.00 (6.68)	GPM (ft/sec)
80°	1.85	2.19	2.55	2.93	3.34	4.22	5.20	6.26	7.41	8.65	9.98	11.38	12.87	14.44	16.09	100% Water
	2.89	3.39	3.93	4.50	5.10	6.40	7.83	9.37	11.04	12.82	14.72	16.73	18.85	21.08	23.42	50% Water/Glycol
100°	1.75	2.07	2.41	2.77	3.16	4.00	4.93	5.95	7.05	8.23	9.49	10.84	12.26	13.76	15.34	100% Water
	2.57	3.02	3.51	4.02	4.47	5.74	7.04	8.44	9.96	11.58	13.31	15.14	17.07	19.11	21.25	50% Water/Glycol
120°	1.67	1.97	2.30	2.65	3.02	3.83	4.72	5.70	6.75	7.89	9.11	10.40	11.77	13.22	14.74	100% Water
	2.35	2.77	3.21	3.69	4.19	5.28	6.48	7.78	9.19	10.70	12.30	14.01	15.81	17.71	19.70	50% Water/Glycol
140°	1.60	1.90	2.21	2.55	2.91	3.69	4.55	5.49	6.51	7.61	8.79	10.04	11.37	12.77	14.24	100% Water
	2.18	2.58	2.99	3.44	3.91	4.94	6.06	7.29	8.61	10.03	11.55	13.16	14.86	16.65	18.53	50% Water/Glycol
160°	1.55	1.83	2.14	2.46	2.81	3.57	4.40	5.32	6.31	7.38	8.52	9.74	11.03	12.39	13.83	100% Water
	2.06	2.43	2.82	3.25	3.69	4.66	5.73	6.90	8.16	9.51	10.95	12.48	14.10	15.81	17.61	50% Water/Glycol
180°	1.50	1.78	2.07	2.39	2.73	3.47	4.28	5.17	6.14	7.18	8.30	9.48	10.74	12.07	13.47	100% Water
	1.96	2.31	2.69	3.10	3.53	4.46	5.48	6.60	7.81	9.11	10.50	11.97	13.53	15.18	16.90	50% Water/Glycol

40 mm R-flex Dual, Pressure Drop per 50' (1.43" Nom. ID)																
°F	7.00 (1.78)	8.00 (2.03)	9.00 (2.28)	10.00 (2.54)	11.00 (2.79)	12.00 (3.05)	13.00 (3.30)	14.00 (3.55)	15.00 (3.81)	16.00 (4.06)	17.00 (4.31)	18.00 (4.57)	19.00 (4.82)	20.00 (5.08)	25.00 (6.34)	GPM (ft/sec)
80°	1.18	1.49	1.83	2.21	2.61	3.05	3.51	4.00	4.52	5.07	5.65	6.25	6.89	7.55	11.24	100% Water
	1.83	2.29	2.80	3.35	3.94	4.57	5.24	5.96	6.71	7.50	8.32	9.19	10.09	11.02	16.24	50% Water/Glycol
100°	1.12	1.41	1.74	2.09	2.49	2.89	3.33	3.80	4.30	4.83	5.38	5.95	6.56	7.19	10.73	100% Water
	1.63	2.05	2.51	3.00	3.54	4.11	4.72	5.37	6.05	6.77	7.53	8.31	9.14	9.99	14.77	50% Water/Glycol
120°	1.06	1.35	1.66	2.00	2.37	2.77	3.19	3.64	4.12	4.63	5.16	5.71	6.30	6.90	10.31	100% Water
	1.49	1.88	2.30	2.76	3.26	3.79	4.36	4.96	5.59	6.26	6.96	7.70	8.46	9.26	13.71	50% Water/Glycol
140°	1.02	1.30	1.60	1.93	2.28	2.67	3.08	3.51	3.98	4.46	4.98	5.51	6.08	6.67	9.97	100% Water
	1.39	1.75	2.15	2.58	3.05	3.55	4.08	4.65	5.24	5.87	6.54	7.23	7.95	8.70	12.91	50% Water/Glycol
160°	0.99	1.25	1.55	1.86	2.21	2.58	2.98	3.40	3.85	4.33	4.83	5.35	5.90	6.47	9.68	100% Water
	1.31	1.65	2.03	2.44	2.88	3.36	3.86	4.40	4.97	5.57	6.20	6.86	7.55	8.27	12.28	50% Water/Glycol
180°	0.96	1.22	1.50	1.81	2.15	2.51	2.90	3.31	3.75	4.21	4.70	5.21	5.74	6.30	9.44	100% Water
	1.25	1.58	1.94	2.33	2.76	3.21	3.70	4.22	4.76	5.34	5.94	6.58	7.24	7.93	11.80	50% Water/Glycol

50 mm R-flex Dual, Pressure Drop per 50' (1.79" Nom. ID)															
°F	11.00 (1.78)	12.00 (1.94)	13.00 (2.11)	14.00 (2.27)	15.00 (2.43)	16.00 (2.59)	17.00 (2.75)	18.00 (2.92)	19.00 (3.08)	20.00 (3.24)	25.00 (4.05)	30.00 (4.86)	35.00 (5.67)	40.00 (6.48)	GPM (ft/sec)
80°	0.90	1.04	1.20	1.37	1.55	1.74	1.93	2.14	2.35	2.58	3.84	5.31	7.00	8.89	100% Water
	1.37	1.59	1.82	2.07	2.33	2.60	2.88	3.18	3.49	3.81	5.61	7.70	10.07	12.72	50% Water/Glycol
100°	0.85	0.99	1.14	1.30	1.47	1.65	1.84	2.03	2.24	2.45	3.65	5.07	6.68	8.50	100% Water
	1.23	1.43	1.64	1.86	2.09	2.34	2.60	2.87	3.15	3.45	5.08	6.99	9.17	11.59	50% Water/Glycol
120°	0.81	0.95	1.09	1.25	1.41	1.58	1.76	1.95	2.15	2.35	3.51	4.87	6.42	8.17	100% Water
	1.13	1.31	1.50	1.71	1.93	2.16	2.40	2.65	2.91	3.19	4.71	6.49	8.52	10.79	50% Water/Glycol
140°	0.78	0.91	1.05	1.20	1.36	1.52	1.70	1.88	2.07	2.27	3.39	4.70	6.21	7.91	100% Water
	1.05	1.22	1.41	1.60	1.81	2.02	2.25	2.48	2.73	2.99	4.43	6.11	8.03	10.18	50% Water/Glycol
160°	0.75	0.88	1.02	1.16	1.31	1.47	1.64	1.82	2.01	2.20	3.29	4.57	6.03	7.69	100% Water
	0.99	1.16	1.33	1.51	1.71	1.91	2.13	2.35	2.59	2.83	4.20	5.81	7.64	9.69	50% Water/Glycol
180°	0.73	0.86	0.99	1.13	1.28	1.43	1.60	1.77	1.95	2.14	3.20	4.45	5.88	7.50	100% Water
	0.95	1.10	1.27	1.45	1.63	1.83	2.04	2.25	2.48	2.72	4.03	5.58	7.34	9.32	50% Water/Glycol

63 mm R-flex Dual, Pressure Drop per 50' (2.25" Nom. ID)														
°F	15.00 (1.53)	20.00 (2.04)	25.50 (2.55)	30.00 (3.08)	35.00 (3.57)	40.00 (4.08)	45.00 (4.59)	50.00 (5.10)	55.00 (5.61)	60.00 (6.13)	65.00 (6.64)	70.00 (7.15)	GPM (ft/sec)	
80°	0.52	0.86	1.27	1.76	2.31	2.94	3.63	4.38	5.20	6.08	7.02	8.02	100% Water	
	0.78	1.28	1.88	2.58	3.37	4.25	5.22	6.27	7.41	8.63	9.93	11.32	50% Water/Glycol	
100°	0.49	0.81	1.21	1.67	2.20	2.80	3.46	4.18	4.97	5.81	6.71	7.67	100% Water	
	0.70	1.15	1.70	2.34	3.06	3.86	4.75	5.72	6.76	7.88	9.08	10.36	50% Water/Glycol	
120°	0.47	0.78	1.16	1.61	2.12	2.69	3.33	4.02	4.78	5.59	6.46	7.39	100% Water	
	0.65	1.06	1.57	2.16	2.83	3.59	4.41	5.32	6.30	7.35	8.47	9.66	50% Water/Glycol	
140°	0.45	0.75	1.12	1.55	2.04	2.60	3.22	3.89	4.62	5.41	6.26	7.16	100% Water	
	0.60	1.00	1.47	2.03	2.67	3.38	4.16	5.02	5.94	6.94	8.00	9.13	50% Water/Glycol	
160°	0.43	0.73	1.08	1.50	1.98	2.52	3.12	3.78	4.49	5.26	6.09	6.97	100% Water	
	0.57	0.94	1.40	1.93	2.53	3.21	3.96	4.78	5.66	6.61	7.63	8.72	50% Water/Glycol	
180°	0.42	0.71	1.05	1.46	1.93	2.46	3.05	3.69	4.38	5.14	5.94	6.80	100% Water	
	0.54	0.90	1.34	1.85	2.43	3.08	3.80	4.59	5.45	6.37	7.35	8.39	50% Water/Glycol	

Appendix C pressure test results

Test the finished pipe-work before concealing! The execution and documentation of the pressure test for the entire piping system is a warranty requirement!

2 Preliminary test	<input type="text" value="psi"/>	3 Main test	<input type="text" value="psi"/>
2.1 Operating pressure x 1,5	<input type="text"/>	3.1.1 Beginning	<input type="text"/>
2.2 After 10 min (restore 2,1)	<input type="text"/>	3.1.2 End	<input type="text"/>
2.3 After 20 min (restore 2,1)	<input type="text"/>	3.2 Test pressure	<input type="text"/>
2.4 After 30min	<input type="text"/>	3.3 After 120 min	<input type="text"/>
2.5 After 60 min admissible pressure drop < 0,6 bar	<input type="text"/>	3.4 Remarks admissible pressure drop < 0,2 bar	<input type="text"/>

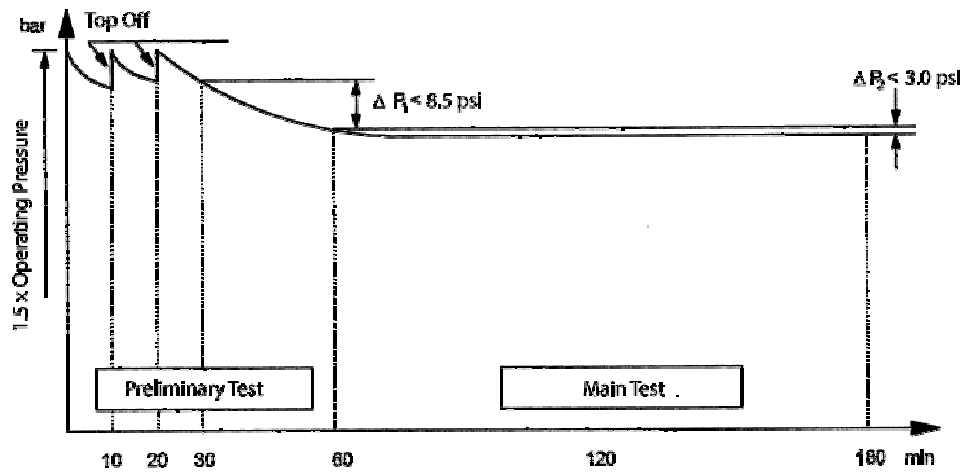

Appendix D installation times

The installation time is highly dependant on local conditions. Obstacles, use of tools and weather can have a significant impact on the installation time.

Outside casing d_{out}	PEX d_{out}	Time per coil	Number of Workers
mm	mm	minutes*	
Single (100m)			
160	40	60	3
160	50	60	3
160	63	60	4
200	75	75	4
200	110	90	5
Double (100m)			
125	1 inch/32mm	40	3
160	40	60	3
200	50	60	3
200	63	60	4

* All installation times are approximate. Transport and digging not included.

Accessories	Time	Number of Workers
	minutes*	
Terminal connections	15-20 min.	1
Tees PEX	30-40 min.	1
Insulation casings	20-30 min.	1
Shrink caps	15 min.	1

* All installation times are approximate. Transport and digging not included.



A Watts Water Technologies Company
4500 E. Progress Place
Springfield, MO 65803
ph: 417.864.6108
800.276.2419
fax: 417.864.8161
www.wattsradiant.com

In Canada

Watts Industries - Canada
5435 North Service Road
Burlington, ON L7L-5H7
ph: 888.208.8927
905.332.4090
fax: 888.882.1979
905.332.7068
www.wattscanada.ca

