

**Feature**

- 150# WSP / 600# WOG
- Lead free brass body
- Full port
- Adjustable packing
- FNPT x FNPT
- Threaded ends (ASME B1.20.1-NPT)
- Blow-out proof stem
- Virgin PTFE seats
- CSA ½, 5 & 125 psi
- CSA ΔC
- UL approved
- AB1953, NSF/ANSI 61 & 372 certified



Pressure/ Temperature rating	
600 psi from 15 °F to 160 °F	150 psi max. at 366 °F

**Material**

	Part	Material	Specification
1	Body	Lead Free Brass	ASTM B927 C27450
2	End piece	Lead Free Brass	ASTM B927 C27450
3	Ball	Lead Free Brass / Cr plated	ASTM B927 C27450
4	Seat	PTFE	PTFE
5	Stem	Lead Free Brass	ASTM B927 C27450
6	O-ring	FKM	NSF approved
7	Packing	PTFE	PTFE
8	Packing nut	Brass	ASTM B124 C37700
9	Wing handle	Steel / Dacromet® plated	A36
10	Handle nut	Steel / Zn plated	A36

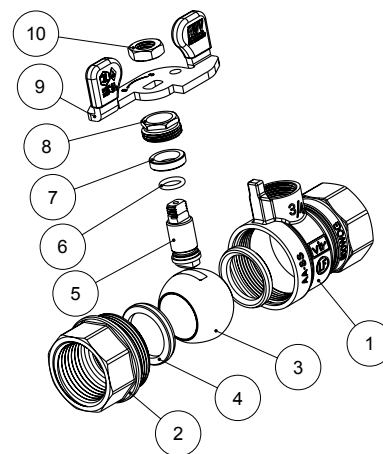

**Dimension**

Size	T	A	C	H	L	P	Cv	Wt. L
		[in]	[in]	[in]	[in]	[in]		[lb]
½"	½ - 14NPT	2.17	0.61	1.93	2.44	0.50	11	0.39
¾"	¾ - 14NPT	2.40	0.63	2.05	2.44	0.73	26	0.53
1"	1 - 11.5NPT	2.91	0.75	2.52	3.27	0.95	55	0.88

