

NIBCO® Press Lead-Free Three Piece Bronze Ball Valves

Features: Silicon Performance Bronze® Alloy • Three-Piece Body • Press Ends Leak Detection • Full Port • Blowout-Proof Stem

Approvals: MSS SP-110/145 • Truesdail NSF/ANSI/CAN 61-2018 Commercial Hot 180°F, NSF/ANSI 372

Size range: 1/2" - 2-1/2"

Pressure rating: 250 psi non-shock cold working pressure*

Maximum pressure / temperature: 225 psi at 250° F*

Lead-free markings: Double oval in body casting, white handle and blue hang tag

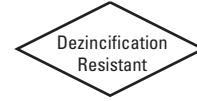

NSF/ANSI/CAN 61-2018



MATERIAL LIST

| PART | SPECIFICATION |
|---------------------------|---|
| 1. Body Nuts | Zinc Dichromate Plated Steel ASTM A449 Grade 5 |
| 2. Handle Nut | Zinc Plated Steel |
| 3. Threaded Pack Gland | Brass ASTM B16 Alloy C36000 |
| 4. Body | Silicon Bronze ASTM B584 Alloy C87850 |
| 5. Body End (2) | Silicon Bronze ASTM B584 Alloy C87850 |
| 6. Handle | Steel, Plated Plastisol Coated DZR Brass SAE J461 C46500 (1/4"-1") |
| 7. Ball | Stainless Steel ASTM A276 S31600 or ASTM A351 CF8M (1 1/4"-2 1/2") |
| 8. Seats (2) | PTFE "Y" or RPTFE "R" Glass Reinforced |
| 9. Body Bolts | Zinc Dichromate Plated Steel ASTM A449 Grade 5 |
| 10. O-ring (2) | FKM |
| 11. Grounding Washer | Stainless Steel- ASTM A-167 304 |
| 12. Thrust Washer | Reinforced PTFE |
| 13. Stem Packing | PTFE |
| 14. Stem | Silicon Bronze ASTM B371 Alloy C69300 |
| 15. Press End Adapter (2) | Wrot Copper ASTM B75 Alloy C12200 |
| 16. O-Ring (2) | EPDM (Leak Detection) |
| 17. Boss Seal O-ring (2) | EPDM |

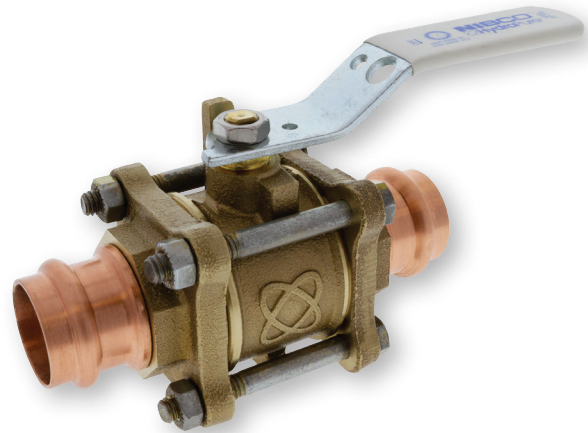

PC-595-Y-LF
PC-595-R-LF

Press

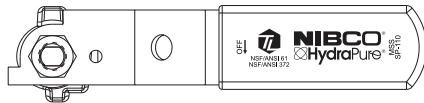
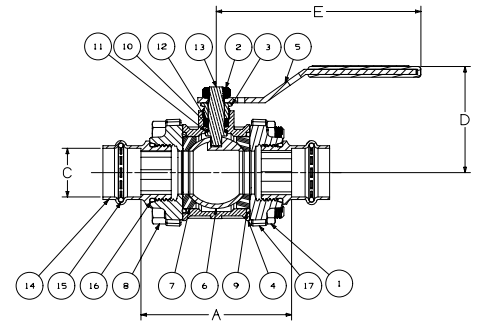
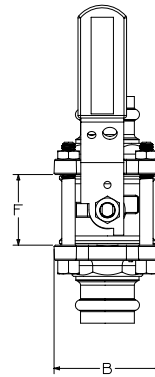

Handle Markings

DIMENSIONS - WEIGHTS - QUANTITIES

| Size | A | | B | | C | | D | | E | | F | | Weights | | Master Ctn. Qty. |
|--------|-------|-----|-------|-----|-------|-----|-------|-----|-------|-----|-------|-----|---------|------|------------------|
| | In. | mm. | In. | mm. | In. | mm. | In. | mm. | In. | mm. | In. | mm. | lbs. | kg | |
| 1/2" | 2.482 | 63 | 1.794 | 46 | 0.629 | 16 | 1.942 | 49 | 3.96 | 101 | 0.968 | 25 | 1.14 | 0.52 | 40 |
| 3/4" | 3.048 | 77 | 1.991 | 51 | 0.881 | 22 | 2.277 | 58 | 4.762 | 121 | 1.281 | 33 | 1.91 | 0.87 | 25 |
| 1" | 3.505 | 89 | 2.484 | 63 | 1.132 | 29 | 2.469 | 63 | 4.762 | 121 | 1.643 | 42 | 2.84 | 1.29 | 15 |
| 1 1/4" | 3.758 | 95 | 2.718 | 69 | 1.382 | 35 | 3.092 | 79 | 6.75 | 171 | 1.83 | 46 | 4.36 | 1.98 | 10 |
| 1 1/2" | 4.24 | 108 | 3.045 | 77 | 1.633 | 41 | 3.335 | 85 | 6.75 | 171 | 2.205 | 56 | 5.73 | 2.60 | 8 |
| 2" | 6.404 | 163 | 4.042 | 103 | 2.134 | 54 | 3.556 | 90 | 6.75 | 171 | 2.72 | 69 | 11.12 | 5.04 | 4 |
| 2 1/2" | 7.071 | 180 | 5.09 | 129 | 2.631 | 67 | 4.322 | 110 | 8.06 | 205 | 3.513 | 89 | 18.79 | 8.52 | 2 |

*200 PSI CWP and 200 PSI at 200°F for 2 1/2" and above



WARNING: This product can expose you to chemicals including lead, which is known to the State of California to cause cancer and birth defects or other reproductive harm. For more information go to www.P65Warnings.ca.gov.

LEAD-FREE: Weighted average lead content ≤ 0.25%