

Thermostatic mixing valves, low-lead, high-flow

5231 series



01256/18.2 NA

Replaces 01256/18.1 NA



Function

The thermostatic mixing valve is used in systems producing domestic hot water or in radiant heating systems. Its function is to maintain the temperature of the mixed water supplied to the user at a constant set value when there are variations in the supply pressure and temperature of the incoming hot and cold water or in the flow rate.

The 5231 series thermostatic mixing valves are ASSE 1017 approved for point of distribution and are designed specifically for systems requiring high flow rates and precise, stable temperature control. Optional stainless steel inlet port check valves are available separately, for field installation only.

This valve is certified by ICC-ES to be in compliance with the International Plumbing Code (IPC), International Residential Code (IRC), Uniform Plumbing Code (UPC), National Plumbing Code of Canada (NPC), and standards ASSE 1017-2009, and CSA B125.3-2012. It is certified by ICC-ES to be in compliance with standard NSF/ANSI 372-2011, Drinking Water System Components – Lead Content Reduction of Lead in Drinking Water Act, California Health and Safety Code 116875 S.3874, Reduction of Lead in Drinking Water Act.

ASSE 1017



Product Range

Code 5231_0A	Thermostatic mixing valve (ASSE 1017) with threaded connections.....	sizes 1", 1-1/4", 1-1/2", 2" NPT male union
Code 5231_8A	Thermostatic mixing valve (ASSE 1017) with sweat connections.....	sizes 1", 1-1/4", 1-1/2", 2" sweat union
Code 5231_9A	Thermostatic mixing valve (ASSE 1017) replacement body without fittings or union nuts.....	sizes 1-1/2", 2" thread union
Code 523177A	Thermostatic mixing valve (ASSE 1017) with sweat connections and outlet temperature gauge.....	size 1-1/4" sweat union

Technical specification

Materials	- Body:	DZR low-lead brass
	- Shutter:	PPSG40
	- Springs:	Stainless steel
	- Seals:	peroxide-cured EPDM
	- Check valve extension (field installed):	Stainless steel

Performance

Suitable fluids:	Water, glycol solutions
Maximum percentage of glycol:	40% glycol solution
Mixed temperature adjustment setting range:	95 – 150°F (35 – 66°C)
Temperature stability:	± 3°F (± 2°C)
Max working pressure (static):	200 psi (14 bar)
Max operating differential pressure:	75 psi (5 bar)
Hot water inlet temperature range:	120 – 195°F (49 – 91°C)
Cold water inlet temperature range:	39 – 80°F (3.9 – 26.6°C)
Maximum inlet pressure ratio (H/C or C/H) for optimum performance:	2:1
Minimum temperature difference between hot water inlet and mixed water outlet for optimum performance:	20°F (11°C)
Maximum water hardness:	10 grains

Certifications

- ASSE 1017/CSA B125.3, certified by ICC-ES, file PMG-1357
- NSF/ANSI 372-2011, Drinking Water System Components-Lead Content Reduction of Lead in Drinking Water Act, California Health and Safety Code 116875 S.3874, Reduction of Lead in Drinking Water Act, certified by ICC-ES, file PMG-1360.

Connections

- | | |
|-------------------|------------------------|
| - NPT male union: | 1", 1-1/4", 1-1/2", 2" |
| - sweat union: | 1", 1-1/4", 1-1/2", 2" |

Dimensions

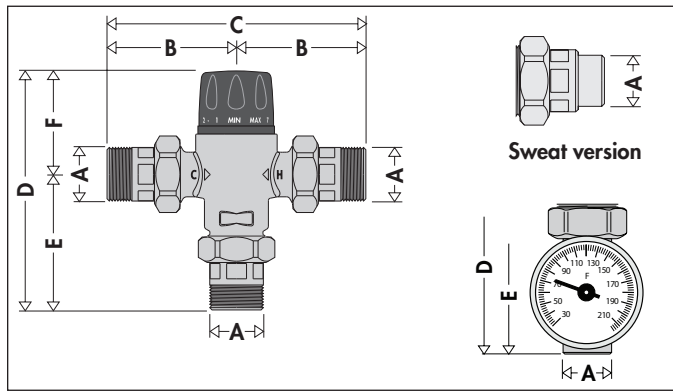

Dimensions with check valves

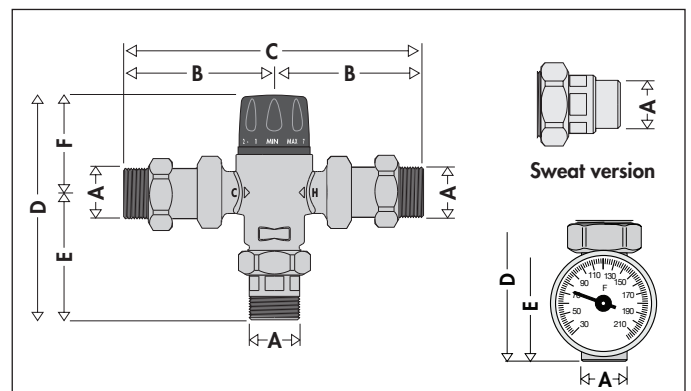

Code	A	B	C	D	E	F	Wt (lb)
523160A	1" NPT	4"	8"	7 5/8"	4 3/16"	3 3/8"	7.0
523168A	1" SWT	3 5/16"	6 5/8"	7"	3 1/2"	3 3/8"	7.0
523170A	1 1/4" NPT	4 1/8"	8 1/4"	7 3/4"	4 5/16"	3 3/8"	7.0
523177A	1 1/4" SWT	3 3/8"	6 3/4"	7 5/8"	4 1/8"	3 3/8"	9.0
523178A	1 1/4" SWT	3 3/8"	6 3/4"	7"	3 1/2"	3 3/8"	7.0
523180A	1 1/2" NPT	5 1/8"	10 1/4"	9 3/16"	5 7/16"	3 3/4"	17
523188A	1 1/2" SWT	4 1/16"	8 1/8"	8 1/8"	4 3/8"	3 3/4"	17
523190A	2" NPT	5 1/8"	10 1/4"	9 1/2"	5 3/4"	3 3/4"	18
523198A	2" SWT	4 5/16"	8 5/8"	8 5/8"	4 7/8"	3 3/4"	18

Code	A	B	C	D	E	F	Wt (lb)
NA10366	1" NPT	5 1/2"	10 7/8"	7 5/8"	4 3/16"	3 3/8"	9.0
	1" SWT	4 3/4"	9 1/2"	7"	3 1/2"	3 3/8"	9.0
	1 1/4" NPT	5 5/8"	11 1/8"	7 3/4"	4 5/16"	3 3/8"	9.0
	1 1/4" SWT	4 3/4"	9 5/8"	7 5/8"	4 1/8"	3 3/8"	11.0
	1 1/4" SWT	4 3/4"	9 5/8"	7"	3 1/2"	3 3/8"	9.0
NA10367	1 1/2" NPT	7 3/8"	14 3/4"	9 3/16"	5 7/16"	3 3/4"	19
	1 1/2" SWT	6 1/4"	12 5/8"	8 1/8"	4 3/8"	3 3/4"	19
	2" NPT	7 3/8"	14 3/4"	9 1/2"	5 3/4"	3 3/4"	20
	2" SWT	6 1/2"	13 1/8"	8 5/8"	4 7/8"	3 3/4"	20

Dimensions for 5231 models with field installed inlet check valve assemblies, code numbers listed in first column.

"Legionella" - Scalding risk

In systems producing domestic hot water with storage, in order to avoid the dangerous bacteria known as "Legionella", the hot water must be stored at a temperature of at least 140°F. At this temperature it is certain that the growth of the bacteria causing this infection will be totally eliminated. However, at this temperature the water cannot be used directly, as it may cause scalding. For example, at 130°F, partial burning takes place in 30 seconds and at 140°F total burning takes place in 5 seconds. In view of the above, it is necessary to install a thermostatic mixing valve which can:

- reduce the temperature at the point of use to a value lower than that of storage;
- maintain this value when the incoming pressure and temperature conditions vary.

Thermal disinfection

The diagram to the right shows the behavior of the bacteria "Legionella Pneumophila" when the temperature conditions of the water in which it is contained vary, in laboratory sample population. In order to ensure proper thermal "disinfection", the value must not be below 140°F.

Reference documents

For the prevention and control of Legionella, see the ASHRAE Standard 12-200 and 188-2015.

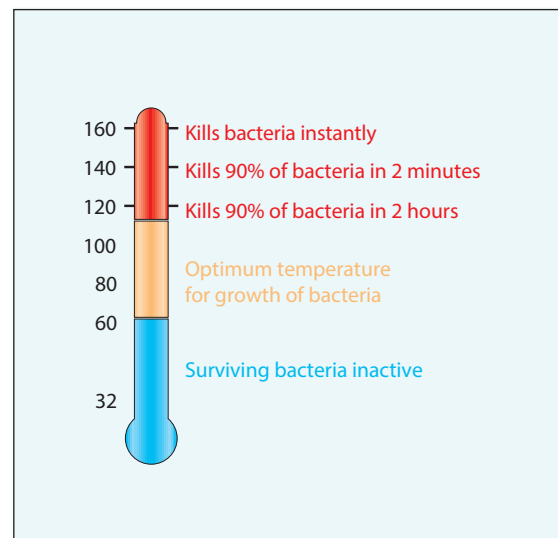

Principle of Operation

A thermostatic mixing valve mixes hot and cold water in such a way as to maintain a constant set temperature of the mixed water at the outlet. A thermostatic element is fully immersed into the mixed water. It then contracts or expands causing movement of the piston, closing either the hot or cold inlets, regulating the flow rates entering the valve. If there are variations of temperature or pressure at the inlets, the internal element automatically reacts attempting to restore the original temperature setting.

The Caleffi 5231 series mixing valves require a minimum temperature differential from hot inlet to mixed water outlet of 20°F (11°C) to ensure the correct operation, and maximum pressure difference between the hot and cold inlet parts no greater than 2:1 ratio. Softened water use is highly recommended as the warranty is voided if used on water with hardness greater than 10 grains.

Construction details

Double seat

The mixing valve has a special actuator which acts on a double water passage seat. This produces a high flow rate with a reduced resistance, at the same time maintaining accurate temperature control.

Anti-wear surfaces

The materials of construction in the 5231 series thermostatic mixing valve reduces the problem of jamming caused by mineral deposits. All the working parts, such as the PPSG40 shutter and peroxide-cured EPDM seals, are made of a special anti-scale material, with a low friction coefficient, providing long term high performance.

Low inertia thermostat

The temperature-sensitive element, the “motor” of the thermostatic mixing valve, is characterized by a low heat inertia; this means that it reacts rapidly to variations in the incoming temperature and pressure conditions, reducing the valve response times.

Temperature setting and locking

The control knob permits temperature setting, between min. and max., in one turn (360°). It also has a tamper-proof system to lock the temperature at the set value.

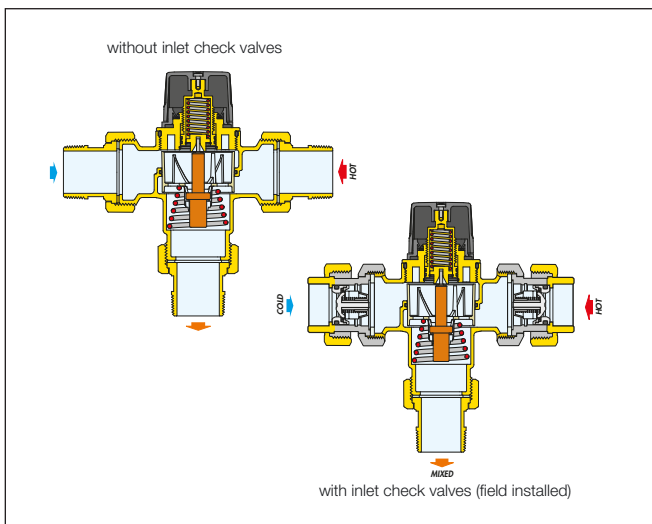

Use

Caleffi 5231 series thermostatic mixing valves are designed to be installed at the hot water heater and cannot be used for tempering water temperature at fixtures as a point-of-use valve. They are not designed to provide scald protection or anti-chill service and should not be used where ASSE 1070 devices are required. For safety reasons, it is advisable to limit the maximum mixed water temperature to 120°F for plumbing applications.

Instantaneous production of hot water

Caleffi 5231 series thermostatic mixing valves are designed for use on domestic water heaters that have storage. The valve may deliver fluctuating mixed temperatures when used on instantaneous domestic water heaters.

Radiant heating systems

Caleffi Series 5231 thermostatic mixing valves can also be used for controlling the flow temperature in radiant heating systems, for constant and accurate control with ease of installation.

Installation

Before installing a Caleffi 5231 series thermostatic mixing valve, the system must be inspected to ensure that operating conditions are within the range of the mixing valve, checking, for example, the supply temperature, supply pressure, etc.

Systems where the Caleffi 5231 series thermostatic mixing valve will be installed must be drained and cleaned out to remove any dirt or debris which may have accumulated during installation. Failure to remove dirt or debris may affect performance and the manufacturer's product guarantee. For heating applications demineralized water use is highly recommended as the warranty is voided if used on water with hardness greater than 10 grains.

The installation of filters of appropriate capacity at the inlet of the water from the supply line is always advisable.

The water must be sufficiently treated before it enters the valve in areas with highly aggressive water. Caleffi 5231 series thermostatic mixing valves must be installed in accordance with the diagrams in this manual, taking into account all current applicable standards.

Caleffi 5231 series thermostatic mixing valves can be installed in any position, either vertical or horizontal.

The following are shown on the thermostatic mixing valves body:

- Hot water inlet, color red.

- Cold water inlet, color blue.

- Mixed water outlet, marked "MIX".

In systems with thermostatic mixing valves, check valves must be installed to prevent undesirable fluid backflow. The 5231 is approved to ASSE 1017, and as such does not contain integral check valves. Caleffi offers inlet port check valve assemblies separately, for field installation only to the 5231 series valve. It is essential that access to the valve is totally unobstructed for any maintenance which may be required to the valve or connections. The piping from/to the valve must not be used to support the weight of the valve itself.

Commissioning

After installation, the valve must be tested and commissioned in accordance with the instructions given below, taking into account current applicable standards.

- 1) The system must be clean and free from any dirt or debris before commissioning the thermostatic mixing valves. Be sure water hardness is less than 10 grains.
- 2) It is recommended that the temperature is set using a suitable calibrated digital thermometer. The valve must be commissioned by measuring the temperature of the mixed water at the outlet.
- 3) The maximum outlet temperature from the valve must be set taking account of the fluctuations due to simultaneous use.
- 4) Adjust the temperature using the adjusting knob on the valve.

For safety reasons, it is advisable to limit the maximum mixed water temperature to 120°F in domestic hot water systems.



Caution: In systems with thermostatic mixing valves, check valves must be installed to prevent undesirable fluid backflow. Separately sourced check valve assemblies for field installation are available for 5231 models.

Locking the setting

Position the knob at the required value, unscrew the top screw, slide off the knob and put it back in such a way that the handle fits into the internal slot of the knob. Tighten the head screw.

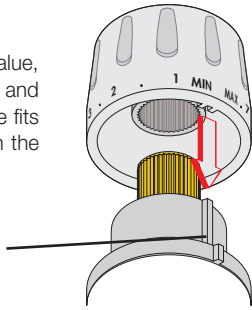

Index Point

Setting the temperature

The temperature is set to the required value by means of the adjusting knob with the graduated scale on the top of the valve.

Pos.	Min	1	2	3	4	5	6	7	Max
T (°F)	95	104	109	117	122	129	136	142	150
T (°C)	35	40	43	47	50	54	58	61	66

with: $T_{HOT} = 155^{\circ}F (68^{\circ}C)$ · $T_{COLD} = 55^{\circ}F (13^{\circ}C)$ · $P_{INLET} = 43 \text{ psi (3 bar)}$

Flow curve

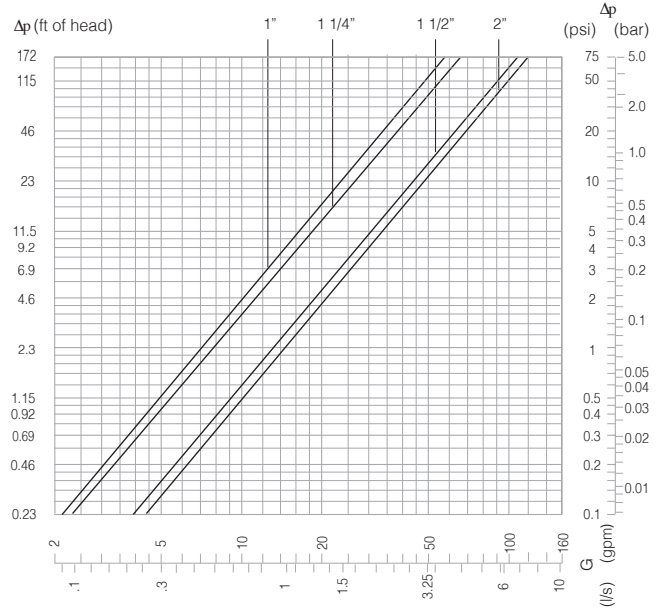

Flow should never exceed standards for pipe size and material.

Flow range

Size	Connection	Model	Min. Flow* (GPM)	Max. Flow* (GPM)	CV
1"	NPT	523160A	4.4	40	7
1"	Sweat	523168A	4.4	40	7
1 1/4"	NPT	523170A	4.4	40	7.6
1 1/4"	Sweat w/ temp gauge	523177A	4.4	40	7.6
1 1/4"	Sweat	523178A	4.4	40	7.6
1 1/2"	NPT	523180A	8.8	70	13
1 1/2"	Sweat	523188A	8.8	70	13
2"	NPT	523190A	8.8	70	14.2
2"	Sweat	523198A	8.8	70	14.2

*Recommended flow rates for temperature stability: $\pm 3^{\circ}F (\pm 2^{\circ}C)$.

Application diagrams

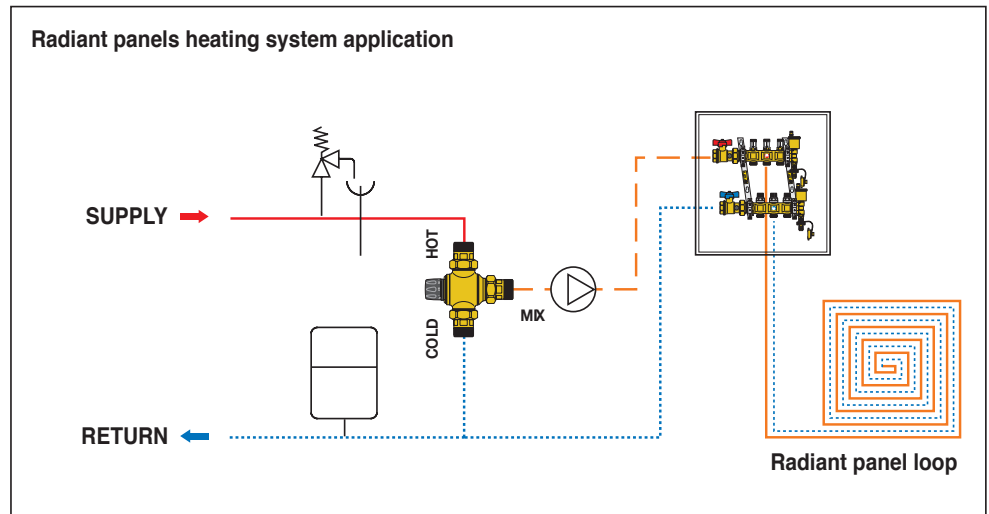
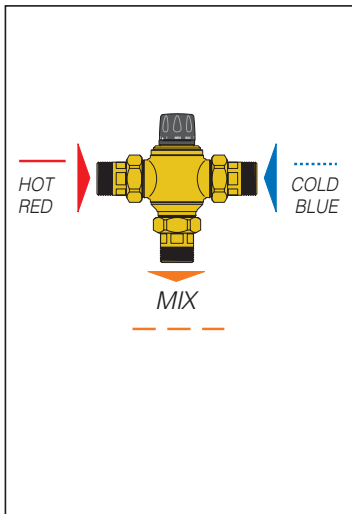

Recirculation with point-of-distribution thermostatic mixing valves

For domestic recirculating systems that include a single ASSE 1017 point-of-distribution thermostatic mixing valve, such as the Caleffi 5231 series thermostatic mixing valves, the piping installation below is recommended.

In any recirculating hot water distribution system there will be times when the circulator is operating, but no hot water is being drawn at the fixtures. Under this condition, heat continually dissipates from the piping forming the recirculation loop. If the loop is relatively short, and well insulated, the rate of heat loss should be very small. If the loop is long, and uninsulated, the rate of heat loss could be substantially greater.

To maintain the recirculating water at the desired delivery temperature the heat lost from the loop must be replaced. This requires some water flow between the loop and the hot water source. Ideally, this flow is adjusted so that the rate of heat transfer from the hot water source to the loop exactly balances the rate of heat loss from the loop's piping.

The figure (below right) shows a "bypass valve" (1), and "return valve" (2), which regulates how much warm water from the return side of the recirculating loop flows back to the storage tank. When there is no demand for hot water at the fixtures, the flow of return water to the tank will equal the rate of hot water flow from the tank to the inlet port of the mixing valve. Ideally, this flow should be adjusted so that the rate of heat transfer from the tank to the recirculating

loop exactly balances the rate of heat loss from the recirculating loop. This allows the water temperature leaving the mixing valve to remain stable.

The bypass valve (1) and possibly the return valve (2) must be adjusted when there is no domestic water draw on the recirculating loop (when all the fixtures are off). Begin with the bypass valve (1) fully closed, and the return valve (2) fully open. Turn on the recirculating circulator and let it run for several minutes. The supply water temperature leaving the mixing valve will likely be lower than the setting of the valve, since there is no return flow to the tank.

Slowly open the bypass valve (1) and monitor the temperature leaving the mixing valve. It will likely begin rising as some water returns to the tank, and an equal flow of hot water moves from the tank to the hot port of the mixing valve. When the temperature leaving the mixing valve remains stable, and is at or very close to the temperature set on the mixing valve, the bypass valve is correctly set.

The return valve (2) can remain fully open unless a situation occurs where the bypass valve (1) is fully open, but the temperature leaving the mixing valve is still too low. If this occurs, partially close the return valve (2) to add flow resistance. This forces more flow through the bypass valve (1). Repeat the previously described procedure of slowly opening the bypass valve (1) until the water temperature leaving the mixing valve is stable.

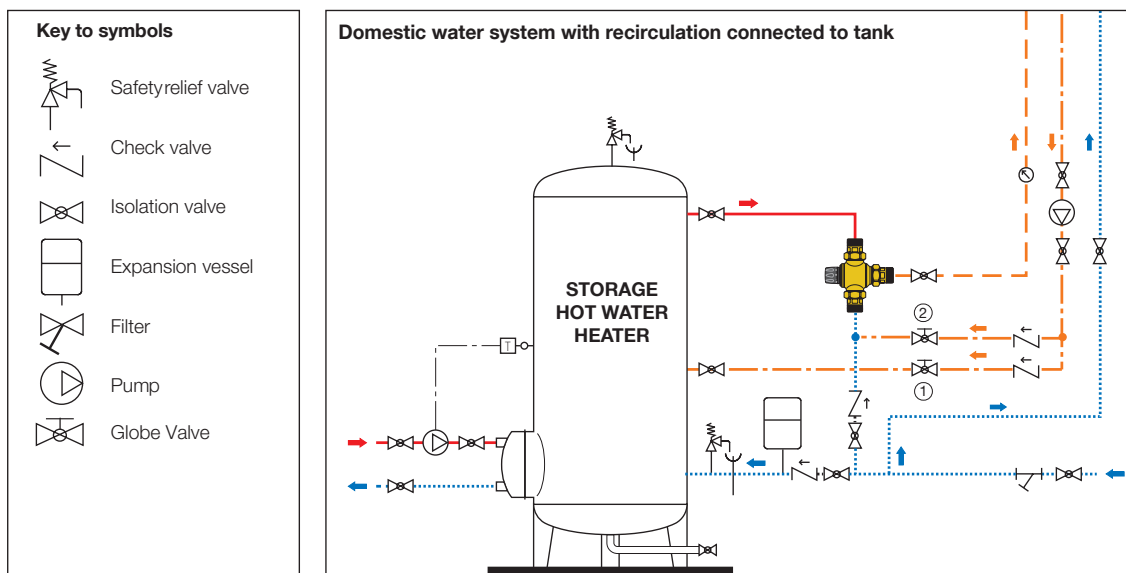

Replacement fittings

Item Description	Item quality per valve	1 inch		1 ¼ inch		1 ½ inch		2 inch	
		NPT	Sweat	NPT	Sweat	NPT	Sweat	NPT	Sweat
		523160A	523168A	523170A	523178A 523177A	523180A	523188A	521390A	523198A
Union Washer	3	R50057				R50060			
Union Nut	3	R31589				R51838			
Male Tailpieces	3	NA10009	31554 FD	R41660	41787 CST (2 ONLY - 177A)	41371A	41788 CST	41372A	F0000496
Inlet Check Valve Assembly- field installed only	2	NA10366				NA10367			
Outlet adapter with temperature gauge	1	NA10476		NA10315		NA10461			
Replacement temperature gauge with pocket well	1	688003A							
Replacement temperature gauge	1	R39591							

Replacement parts



Point of distribution mixed temperature gauge adaptor fits high flow 5231 series mixing valves. Removable gauge fits into temperature well.

Gauge dial is 2" diameter and scale from 30—210° F.

Low-lead brass body.



5231 High Flow Body

Replacement body.

Certified to ASSE 1017/CSA B125.3, by ICC-ES, file PMG-1357 and NSF/ANSI 372-2011, Low lead brass, by ICC-ES, file PMG-1360.

ASSE 1017



Code	Description	Lbs
NA10315	1¼" sweat with gauge	0.5
NA10476	For 1" & 1 ¼" *	3.0
NA10476	For 1 ½" & 2" *	4.0
688003A	Replacement gauge with pocket well	0.2
R39591	Replacement temperature gauge	0.2

Code	Description	Min. Flow (gpm)	Cv	Lbs
523179A	1½" union thread	4.4	7.6	5.0
523199A	2½" union thread	8.8	14.2	15.0

Includes no fittings or union nuts.

* Requires separately ordered union nut, tailpiece and union washer. See replacement fittings table above.



Inlet check valve assembly for mounting on inlet union tail pieces of 5231 mixing valves.

Stainless steel body, acetal plastic check valve insert with NBR o-ring.

Code	Description	Open Pressure	Lbs
NA10366	Check valve assembly 1" & 1¼"	0.23 psi	1.0
NA10367	Check valve assembly 1½" & 2"	0.20 psi	1.5

NOTES

SPECIFICATION SUMMARIES

5231 series

Adjustable thermostatic mixing valve. ASSE 1017/CSA B125.3 certified by ICC-ES. Threaded NPT or sweat connections from 1" to 2" with unions and tailpieces. DZR low-lead brass body (<0.25% lead content), meets requirements of IPC, IRC, UPC, NPC and ANSI/NSF 372-2011 certified by ICC-ES. PPSG40 shutter, stainless steel springs, and peroxide-cured EPDM seals. Maximum working pressure 200 psi (14 bar). Maximum operating differential pressure 75 psi (5 bar). Mixed temperature setting range 95°F to 150°F (35°C to 66°C), Temperature stability $\pm 3^\circ\text{F}$ ($\pm 2^\circ\text{C}$). Maximum water hardness: 10 grains. Provided with tamper-proof temperature locking. Provide with optional mixed outlet temperature gauge for 1 1/4" union sweat model, 30°F to 210°F scale, 2 inch diameter. Provide with optional stainless steel inlet port check valve assembly with an acetal plastic check valve insert and NBR o-ring, field installed.

We reserve the right to change our products and their relevant technical data, contained in this publication, at any time and without prior notice.



Caleffi North America, Inc.
3883 W. Milwaukee Road
Milwaukee, WI 53208
Tel: 414-238-2360 · Fax: 414-238-2366
sales@caleffi.com · www.caleffi.com
© Copyright 2018 Caleffi North America, Inc.