

FlowCal™ Automatic flow balancing valve with polymer cartridge

© Copyright 2018 Caleffi

121 Series



Function

The FlowCal™ automatic flow balancing valve maintains a constant fixed flow rate within varying system differential pressure ranges. Operation is fully automatic requiring no manual adjustment. The 121 series utilize an exclusive, interchangeable flow cartridge, made of anti-scale, low noise polymer for use in cooling and heating systems. The FlowCal 121 series automatic flow balancing valves are available with integral shut-off ball valve and optional factory-installed pressure and temperature test ports.

Drain valves are also available as an accessory for installing in the blowdown port connection.

These items are designed for use in closed hydronic systems. Do not use in plumbing applications. These items do not meet the low-lead plumbing standards of U.S. and Canada.

Product range

121 Series Automatic flow balancing valve with polymer cartridge, ball valve, with and without Pressure and Temperature Test ports; sizes 1/2" - 3/4" - 1" - 1 1/4"

Technical characteristics

Material:	Body:	brass
	FlowCal flow cartridge:	anti-scale polymer
	Spring:	stainless steel
	Seals:	peroxide-cured EPDM
	Ball:	brass, chrome-plated
	Ball seat and stem seal:	PTFE
	Lever:	zinc coated steel with vinyl grip
	Pressure and temperature test port plugs:	brass
	Pressure and temperature test ports:	body and cap- brass; core- nordel
	Drain port plug:	brass
Performance:	Medium:	water, glycol solutions
	Max. percentage of glycol:	50%
	Max. working pressure:	400 psi (400 WOG)
	Working temperature range:	32-212°F (0-100°C)
Connections:	1/2", 3/4", 1", 1-1/4" FNPT or Sweat with union x FNPT or Sweat	
Pressure and temperature test ports connections:	1/4" FNPT	
Blowdown port connection:	1/2" - 3/4": 1/4" FNPT	
	1" - 1 1/4": 1/2" FNPT	
Flow rate:	27 flow rate settings ranging from 0.5 - 21 GPM	
Flow accuracy:	±10%	
Differential Pressure Control Ranges:	2-14, 2-32, 4-34, 5-35, 3-32, 4-35	
Identification:	metal plate with ball chain stating ΔP range and fixed flow rate	



SAFETY INSTRUCTION

This safety alert symbol will be used in this manual to draw attention to safety related instructions. When used, the safety alert symbol means **ATTENTION! BECOME ALERT! YOUR SAFETY IS INVOLVED! FAILURE TO FOLLOW THESE INSTRUCTIONS MAY RESULT IN A SAFETY HAZARD.**



WARNING: This product can expose you to chemicals including lead, which is known to the State of California to cause cancer and birth defects or other reproductive harm. For more information go to www.P65Warnings.ca.gov.



CAUTION: All work must be performed by qualified personnel trained in the proper application, installation, and maintenance of systems in accordance with all applicable codes and ordinances.



CAUTION: Over-tightening and breakage can occur with the use of Teflon® pipe joint compounds. Teflon® provides lubricity so that care must be exercised not to over-tighten joints. Failure to follow these instructions could result in property damage and /or personal injury.



WARNING: System fluids are under pressure or temperature can be hazardous. Be sure the pressure has been reduced to zero and the system temperature is below 100°F (38°C). Failure to follow these instructions could result in property damage and/or personal injury.



WARNING: Clean the pipes of any debris, rust, incrustations, welding slag and any other contaminants. For optimal operation, air in the system must be removed.

Installation

Install the FlowCal™ automatic flow balancing valves on the circuit return pipe with flow direction arrows indicating proper flow direction. It is important to allow easy access to the FlowCal for inspection and maintenance.

The identification tag with the technical data must accompany the balancing valve after installation. It is equipped with a special metal retaining ball chain especially useful when the valve is enclosed with insulation.

Install a Y-strainer (series 120 on circuit supply pipe of the emitter coil to prevent clogging. Strainers should be inspected and cleaned after start-up and twice per year thereafter.

FlowCal™ balancing valves may be installed in the pipe horizontally, vertically or at any angle.

For Sweat fittings: Union sweat tailpieces should be removed from the valve body for sweating to the pipeline. Remove the flow cartridge (and adapter for larger sizes) and pressure port plugs while sweating the fixed end into the pipeline. In addition, wrap a wet cloth around the ball valve portion of the series 121 flow balancing valve (and the 120 Y-strainer) when sweating in the integral sweat body connection.

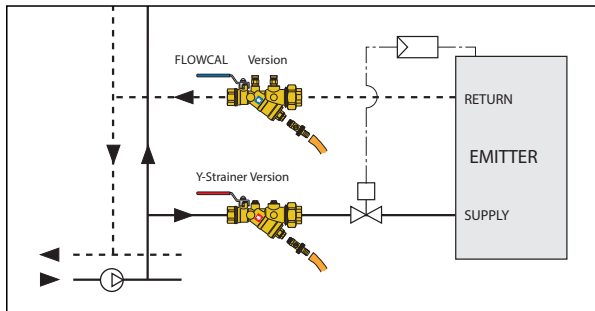

FlowCal cartridge assembly and disassembly

The internal flow cartridge can be removed easily from the valve body for inspection, cleaning or replacement by unscrewing the cap as shown here.

Flow verification

The flow rate can not be field adjusted. To verify flow rate with pressure and temperature gages or meter with sensor probes, use the factory-installed pressure and temperature test ports (or install separately sourced PT test ports, also available from Caleffi). The PT test port accepts either a 1/16" or 1/8" OD probe. Dirt or debris may be the cause for readings outside the specified flow rate.

1/2" - 3/4" from 0.5 to 10 gpm

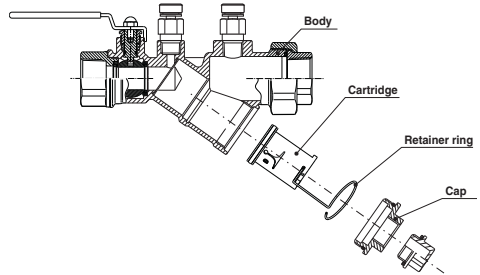

1" - 1 1/4" from 2.5 to 10 gpm

from 11 to 21 gpm

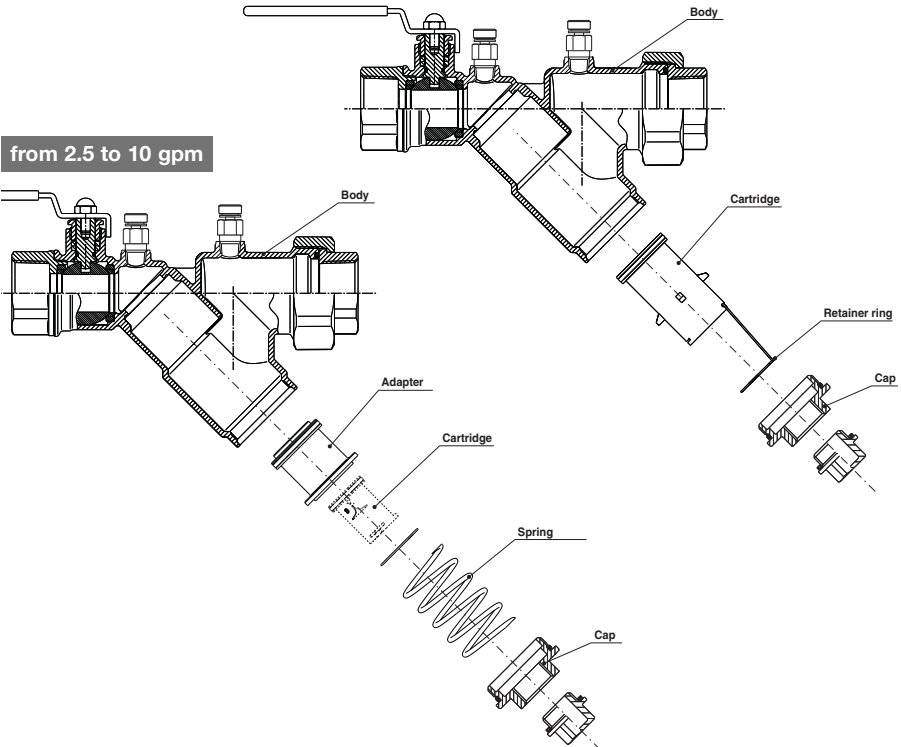

Pressure and temperature testing

The FlowCaI™ body is fitted with connections for the pressure and temperature ports, which is useful when checking operation in the working range. In addition, drain valve (538202 FD -1/4" NPT; 538402 FD-1/2" NPT) can be connected for blowdown operations.

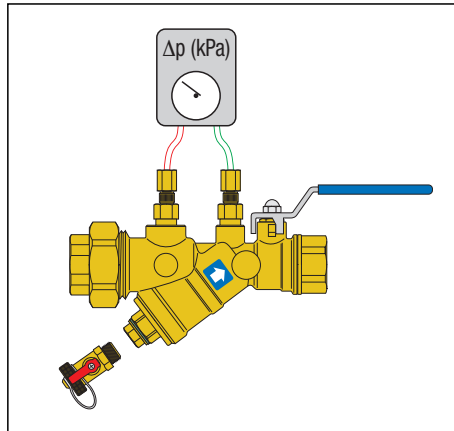

CAUTION: If the FlowCaI™ valve is not installed, commissioned and maintained properly, according to the instructions contained in this manual, it may not operate correctly and may endanger the user.



CAUTION: Make sure that all the connecting pipework is water tight.

Scan to view .



Installation Tip

CALEFFI
Hydronic Solutions

7-23-18

Caleffi North America, Inc.
3883 West Milwaukee Road
Milwaukee, WI 53208
T: 414.238.2360 F: 414.238.2366