



# EXTROL® L SERIES REPLACEMENT BLADDER INSTRUCTIONS

## Models 200-L through 15000-L

**NOTE:** Inspect for shipping damage and notify freight carrier or store where purchased immediately if damage is present. To avoid risk of personal injury and property damage, if the product appears to be malfunctioning or shows signs of corrosion, call a qualified professional immediately. Current copies of the Product manual can be viewed at [www.amtrol.com](http://www.amtrol.com). Use proper safety equipment when installing.



**THIS IS THE SAFETY ALERT SYMBOL. IT IS USED TO ALERT YOU TO POTENTIAL PERSONAL INJURY AND OTHER HAZARDS. OBEY ALL SAFETY MESSAGES THAT FOLLOW THIS SYMBOL TO REDUCE THE RISK OF PERSONAL INJURY AS WELL AS PROPERTY DAMAGE.**

**WARNING** READ CAREFULLY THE EXTROL REPLACEMENT BLADDER INSTRUCTIONS TO AVOID SERIOUS PERSONAL INJURY AND PROPERTY HAZARDS AND TO ENSURE SAFE USE AND PROPER CARE OF THIS PRODUCT.

**WARNING** EXPLOSION OR RUPTURE HAZARD. THE EXPANSION TANK MUST BE OPERATED SO THAT THE PRESSURE DOES NOT EXCEED THE MAXIMUM WORKING PRESSURE.

**WARNING** This Product, like most Products under pressure, may over time corrode, weaken and burst or explode, causing serious or fatal injury, leaking or flooding and/or property damage. To minimize risk, a licensed professional must install and periodically inspect and service the Product. A drip pan connected to an adequate drain must be installed if leaking or flooding could cause property damage. Do not locate in an area where leaking could cause property damage to the area adjacent to the appliance or to lower floors of the structure.

**WARNING** This product can expose you to chemicals including lead, which is known to the State of California to cause cancer and birth defects or other reproductive harm. For more information go to [www.P65Warnings.ca.gov](http://www.P65Warnings.ca.gov).

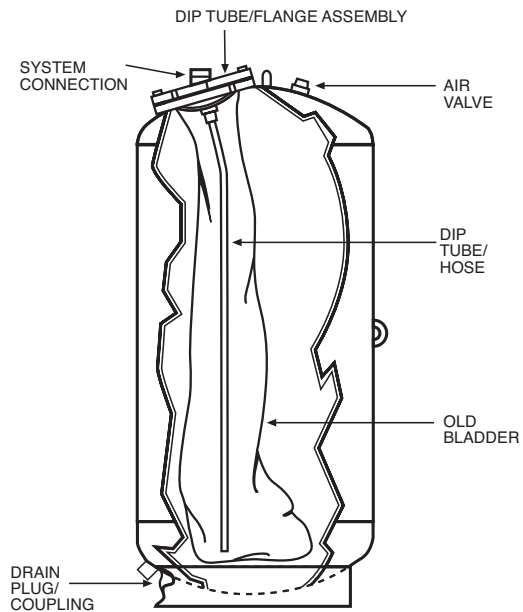

## Installation

**WARNING** THIS PRODUCT MUST BE INSTALLED BY A LICENSED PROFESSIONAL.

1. Isolate tank from system.
2. Release system pressure from tank.
3. Remove air valve core to bleed remaining air charge (Figure 1).
4. Remove drain plug (Figure 2).
5. Disconnect system connection.

6. Mark mating flanges in order to match when re-assembling (Figure 3).
7. Remove bolted upper flange and dip tube/hose.
8. Attached to the upper flange is the bladder support and dip tube/hose (Figure 4). Replace the dip tube/hose with the new one provided in package.
9. Using a pump, remove any remaining water inside of bladder.
10. Using a chain block, lift bladder out of the tank with a twisting motion.

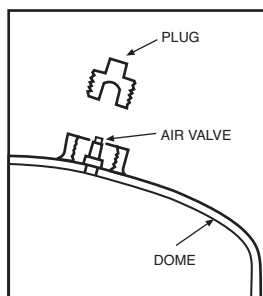

Figure 1

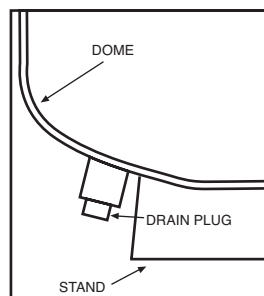

Figure 2

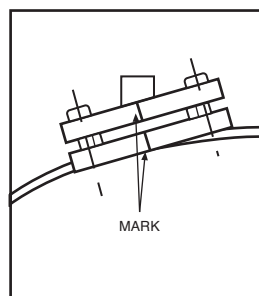

Figure 3

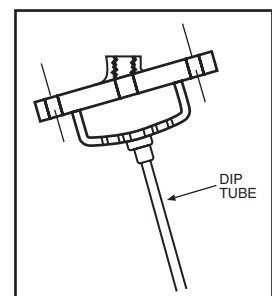

Figure 4

11. Pump out water remaining in very bottom of tank.
12. Wash down inside walls of tank as necessary.
13. Mop up remaining water.
14. Dry out inside of tank (reversed vacuum cleaner or air line from a compressor).
15. Clean out any remaining dirt.
16. Examine interior for any rust blisters and remove them.
17. Roll up the new AMTROL® bladder and tape as necessary intervals to keep it rolled (Figure 5).
18. Insert new bladder removing tape as it nears the tank.
19. Arrow on bladder flange must be pointing to top of tank (Figure 6).
20. Using a long wooden stick (broom handle), clear a path for the dip tube/hose.

**⚠ WARNING FAILURE TO PROPERLY SEAL VALVE CAP WILL RESULT IN LOSS OF PRE-CHARGE CAUSING TANK TO FAIL.**

21. Insert dip tube/hose in bladder and assemble upper flange using alignment marks from Step 6.
22. With flanges aligned, tighten bolt evenly. Torque to 40-50 ft. lbs.
23. Install drain plug (Fig. 2) using a liberal amount of TITE-SEAL COMPOUND 55 or equal. This connection must be absolutely airtight.
24. Install air valve core. Charge tank to equal system pressure using dry air or nitrogen.

**⚠ WARNING DANGER! EXPLOSION HAZARD. IF YOU ADJUST THE PRE-CHARGE PRESSURE OR ADD PRESSURE TO A TANK THAT IS CORRODED OR DAMAGED OR WITH DIMINISHED INTEGRITY, THE TANK CAN BURST OR EXPLODE, POSSIBLY CAUSING SERIOUS OR FATAL PERSONAL INJURY AND/OR PROPERTY DAMAGE.**

- ONLY ADJUST THE PRE-CHARGE AS DESCRIBED IN THIS MANUAL WHEN THE TANK IS NEW OR WHEN THE INTEGRITY OF THE TANK AND LACK OF INTERNAL OR EXTERNAL CORROSION IS CONFIRMED.
- ONLY QUALIFIED PROFESSIONALS SHOULD CHECK, ADJUST OR RE-CHARGE THE PRE-CHARGE OF TANKS.

**⚠ IMPORTANT:** If increasing pre-charge pressure above 55 psig the following steps must be followed:

- a. Tank must be connected to the system with isolation valve open.
- b. System must be pressurized to 13-14 psig or slightly above factory setting.
- c. Isolation valve needs to be shut.
- d. Pre-charge pressure of tank can now be increased to match system fill pressure.
- e. Open isolation valve and start up system.

**Failure to follow these steps could result in damage to the bladder and void all warranties.**

25. Using soapy water, check the drain fitting threads, air valve core and flange joint for leakage.
26. Connect tank to system. Open fill-valve and check operation. Always pre-charge tank before completing this step.

**FAILURE TO FOLLOW ALL WARNINGS MAY RESULT IN SERIOUS INJURY OR FATAL PERSONAL INJURY AND/OR PROPERTY DAMAGE AND WILL VOID THE WARRANTY.**

## Warranty

Replacement Bladder: One (1) Year Limited Warranty

Visit [www.amtrol.com](http://www.amtrol.com) for complete warranty details.

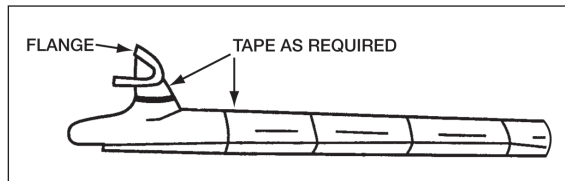

Figure 5

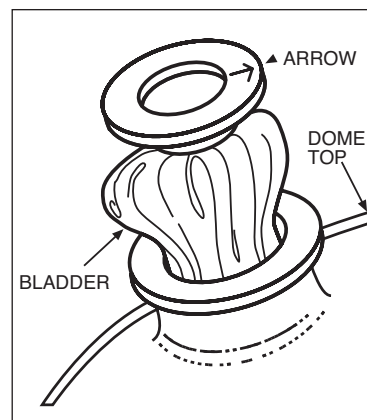

Figure 6

## Required Tooling & Supplies:

1. New AMTROL Bladder Kit
2. Plumbers Tool Box
3. Source of Compressed Dry Air or Nitrogen
4. Portable pump with 20 ft. suction hose
5. Light with 20 ft. Cord
6. Power Extension Cord (as required)
7. Chain Block
8. Pressure Gauge and Air Valve Tool
9. Long wooden stick (broom handle) at least 1 ft. longer than tank height



1400 Division Road, West Warwick, RI USA 02893  
T: 800.426.8765 [www.amtrol.com](http://www.amtrol.com)

